



City of Chaska Local Water Supply Plan

Formerly called Water Emergency & Water Conservation Plan



Table of Contents

PART 1. WATER SUPPLY SYSTEM DESCRIPTION AND EVALUATION..... 4

- A. Analysis of Water Demand..... 4
- B. Treatment and Storage Capacity 6
- C. Water Sources..... 7
- D. Future Demand Projections – *Key Metropolitan Council Benchmark* 8
- E. Resource Sustainability 9
- F. Capital Improvement Plan (CIP)..... 14

PART 2. EMERGENCY PREPAREDNESS PROCEDURES 17

- A. Federal Emergency Response Plan 17
- B. Operational Contingency Plan 17
- C. Emergency Response Procedures 17

PART 3. WATER CONSERVATION PLAN 23

- Progress since 2006 24
- A. Triggers for Allocation and Demand Reduction Actions..... 25
- B. Conservation Objectives and Strategies – *Key benchmark for DNR* 25
 - Objective 1: Reduce Unaccounted (Non-Revenue) Water loss to Less than 10% 25
 - Objective 2: Achieve Less than 75 Residential Gallons per Capita Demand (GPCD) 27
 - Objective 3: Achieve at least a 1.5% per year water reduction for Institutional, Industrial, Commercial, and Agricultural GPCD over the next 10 years or a 15% reduction in ten years. 28
 - Objective 4: Achieve a Decreasing Trend in Total Per Capita Demand 29
 - Objective 5: Reduce Peak Day Demand so that the Ratio of Average Maximum day to the Average Day is less than 2.6..... 29
 - Objective 6: Implement a Conservation Water Rate Structure and/or a Uniform Rate Structure with a Water Conservation Program 29
 - Objective 7: Additional strategies to Reduce Water Use and Support Wellhead Protection Planning 32
 - Objective 8: Tracking Success: How will you track or measure success through the next ten years? 32
- C. Regulation 33
- D. Retrofitting Programs 33
- E. Education and Information Programs..... 34

PART 4. ITEMS FOR METROPOLITAN AREA COMMUNITIES 37

 A. Water Demand Projections through 2040..... 37

 B. Potential Water Supply Issues 37

 C. Proposed Alternative Approaches to Meet Extended Water Demand Projections 37

 D. Value-Added Water Supply Planning Efforts (Optional)..... 38

GLOSSARY 39

 Acronyms and Initialisms 41

Appendix List

- APPENDIX 1: WELL RECORDS AND MAINTENANCE SUMMARIES
- APPENDIX 2: WATER LEVEL MONITORING PLAN
- APPENDIX 3: WATER LEVEL GRAPHS FOR EACH WATER SUPPLY WELL
- APPENDIX 4: CAPITAL IMPROVEMENT PLAN
- APPENDIX 5: EMERGENCY TELEPHONE LIST
- APPENDIX 6: COOPERATIVE AGREEMENTS FOR EMERGENCY SERVICES
- APPENDIX 7: MUNICIPAL CRITICAL WATER DEFICIENCY ORDINANCE
- APPENDIX 8: GRAPH SHOWING ANNUAL PER CAPITA WATER DEMAND FOR EACH CUSTOMER CATEGORY DURING THE LAST TEN-YEARS
- APPENDIX 9: WATER RATE STRUCTURE
- APPENDIX 10: ADOPTED OR PROPOSED REGULATIONS TO REDUCE DEMAND OR IMPROVE WATER EFFICIENCY
- APPENDIX 11: IMPLEMENTATION CHECKLIST

Complete Table 1 with information about the public water supply system covered by this WSP.

Table 1. General information regarding this WSP

Requested Information	Description
DNR Water Appropriation Permit Number(s)	75-6124
Ownership	Public
Metropolitan Council Area	Yes -Carver County
Street Address	City of Chaska 660 Victoria Drive
City, State, Zip	Chaska, MN 55318
Contact Person Name	Matt Haefner
Title	Water and Sewer Superintendent
Phone Number	952-227-7733
MDH Supplier Classification	Municipal

PART 1. WATER SUPPLY SYSTEM DESCRIPTION AND EVALUATION

The first step in any water supply analysis is to assess the current status of demand and availability. Information summarized in Part 1 can be used to develop Emergency Preparedness Procedures (Part 2) and the Water Conservation Plan (Part 3). This data is also needed to track progress for water efficiency measures.

A. Analysis of Water Demand

Complete Table 2 showing the past 10 years of water demand data.

- Some of this information may be in your Wellhead Protection Plan.
- If you do not have this information, do your best, call your engineer for assistance or if necessary leave blank.

If your customer categories are different than the ones listed in Table 2, please describe the differences below:

None

Table 2. Historic water demand (see definitions in the glossary after Part 4 of this template)

Year	Pop. Served	Total Connections	Residential Water Delivered (MG)	C/I/I Water Delivered (MG)	Water used for Non-essential	Wholesale Deliveries (MG)	Total Water Delivered (MG)	Total Water Pumped (MG)	Water Supplier Services	Percent Unmetered/Unaccounted	Average Daily Demand (MGD)	Max. Daily Demand (MGD)	Date of Max. Demand	Residential Per Capita Demand (GPCD)	Total per capita Demand (GPCD)
2005	19,522	5,697	609.146	299.182	-	-	908.328	1,039.000	31,000	12.6%	2.85	7.72	-	85.5	145.8
2006	20,543	5,923	719.074	369.788	-	-	1,088.862	1,189.000	36,000	8.4%	3.26	8.37	7/12/2006	95.9	158.6
2007	21,392	6,039	761.395	392.262	-	-	1,153.657	1,237.000	38,000	6.7%	3.39	8.18	7/22/2007	97.5	158.4
2008	22,501	6,095	702.854	376.045	-	-	1,078.899	1,140.000	38,000	5.4%	3.12	6.31	7/3/2008	85.6	138.8
2009	23,233	6,147	733.221	387.682	-	-	1,120.903	1,156.000	40,000	3.0%	3.17	6.96	7/11/2009	86.5	136.3
2010	23,770	6,213	508.186	527.979	-	-	1,036.165	1,060.000	40,000	2.2%	2.90	5.74	8/9/2010	58.6	122.2
2011	23,984	6,293	498.075	546.618	-	-	1,044.693	1,106.000	41,000	5.5%	3.03	5.95	6/7/2011	56.9	126.3
2012	24,097	6,369	561.866	596.434	-	-	1,158.300	1,212.300	43,000	4.5%	3.32	7.52	7/15/2012	63.9	137.8
2013	24,472	6,454	493.512	538.184	-	-	1,031.696	1,089.100	42,000	5.3%	2.98	6.85	8/26/2013	55.3	121.9
2014	24,854	6,621	450.136	522.367	-	-	972.503	1,036.200	42,000	6.1%	2.84	6.43	8/7/2014	49.6	114.2
2015	25,199	6,813	465.308	525.976	-	-	991.284	1,030.500	43,000	3.8%	2.82	6.01	8/14/2015	50.6	112.0
Avg. 2010-2015	24,396	6,461	496.181	542.926	-	-	1,039.107	1089.017	41,800	4.6%	2.98	6.41	-	55.8	122.4

MG – Million Gallons

MGD – Million Gallons per Day

GPCD – Gallons per Capita per Day

Complete Table 3 by listing the top 10 water users by volume, from largest to smallest. For each user, include information about the category of use (residential, commercial, industrial, institutional, or wholesale), the amount of water used in gallons per year, the percent of total water delivered, and the status of water conservation measures.

Table 3. Large volume users

Customer	Use Category (Residential, Industrial, etc.)	Amount Used (Gallons per Year)	Percent of Total Annual Water Delivered	Implementing Water Conservation Measures? (Yes/No/Unknown)
UNITED HEALTH CARE	Industrial	34,711,000	3.5%	Unknown
ARYZTA LLC (Chef Solutions)	Industrial	20,893,000	2.1%	Unknown
LIFE CORE BIOMEDICAL	Industrial	20,432,000	2.1%	Unknown
TEL FSI INC	Industrial	19,039,000	1.9%	Unknown
BECKMAN COULTER	Industrial	15,874,000	1.6%	Unknown
CHASKA PUBLIC SCHOOL	Commercial	12,296,000	1.2%	Yes
AMER BLUE RIBBON HOLDINGS (VICORP)	Industrial	8,430,000	0.9%	Unknown
ENTEGRIS	Industrial	4,979,000	0.5%	Unknown
NORTHERN STAR	Industrial	3,722,000	0.4%	Unknown
LAKE REGION MEDICAL	Industrial	3,518,000	0.4%	Unknown

B. Treatment and Storage Capacity

Complete Table 4 with a description of where water is treated, the year treatment facilities were constructed, water treatment capacity, the treatment methods (i.e. chemical addition, reverse osmosis, coagulation, sedimentation, etc.) and treatment types used (i.e. fluoridation, softening, chlorination, Fe/MN removal, coagulation, etc.). Also describe the annual amount and method of disposal of treatment residuals. Add rows to the table as needed.

Table 4. Water treatment capacity and treatment processes

Treatment Site ID (Plant Name or Well ID)	Year Constructed	Treatment Capacity	Treatment Method	Treatment Type	Annual Amount of Residuals	Disposal Process for Residuals	Do You Reclaim Filter Backwash Water?
WTP Victoria Dr.	2006	12.6 MGD	Aeration Filtration Chem. addition	Fe/MN Removal Chlorination Fluoridation	1,421,312	Sanitary Sewer	Yes
Well 7	1996	1,750 GPM	Chem. addition	Chlorination Fluoridation	- -	-	
Total	NA	-	NA	NA	1,421,312	NA	NA

Complete Table 5 with information about storage structures. Describe the type (i.e. elevated, ground, etc.), the storage capacity of each type of structure, the year each structure was constructed, and the primary material for each structure. Add rows to the table as needed.

Table 5. Storage capacity, as of the end of the last calendar year

Structure Name	Type of Storage Structure	Year Constructed	Primary Material	Storage Capacity (Gallons)
Symphony Hills	Elevated storage	2007	Steel	750,000
Hundertmark Tower	Elevated storage	2001	Steel	1,500,000
NE Industrial Tower	Elevated storage	1971	Steel	1,500,000
Ground Reservoir	Ground reservoir	1941	Concrete	300,000
Total	NA	NA	NA	4,050,000

Treatment and storage capacity versus demand

It is recommended that total storage equal or exceed the average daily demand. Discuss the difference between current storage and treatment capacity versus the water supplier’s projected average water demand over the next 10 years (see Table 7 for projected water demand):

The Victoria Dr. WTP capacity of 12.6 MGD exceeds the projected 2025 maximum day of 9.4 MGD and the 2040 demand of 11.7 MGD. The existing firm water supply is 9.5 MGD (one well out of service). Therefore, additional water supply will be required around 2025.

The existing storage volume of 4.05 MG exceeds the projected 2025 average day demand of 3.7 MGD. However, growth in the southwest portion of Chaska will lead the City to build additional elevated water storage at that time. The 2040 average day demand is projected to be 4.7 MGD.

C. Water Sources

Complete Table 6 by listing all types of water sources that supply water to the system, including groundwater, surface water, interconnections with other water suppliers, or others. Provide the name of each source (aquifer name, river or lake name, name of interconnecting water supplier) and the Minnesota unique well number or intake ID, as appropriate. Report the year the source was installed or established and the current capacity. Provide information about the depth of all wells. Describe the status of the source (active, inactive, emergency only, retail/wholesale interconnection) and if the source facilities have a dedicated emergency power source. Add rows to the table as needed for each installation.

Include copies of well records and maintenance summary for each well that has occurred since your last approved plan in **Appendix 1**.

Table 6. Water sources and status

Resource Type (Groundwater, Surface water, Interconnection)	Resource Name	MN Unique Well # or Intake ID	Year Installed	Capacity (Gallons per Minute)	Well Depth (Feet)	Status of Normal and Emergency Operations (Does this Source have a Dedicated Emergency Power Source? (Yes or No)
GW, Well 4	Tunnel City/Wonewoc /Mt Simon	200809	1972	1,370	813 ft	Active	Yes
GW, Well 5	Wonewoc/Mt Simon	110453	1975	1,700	773 ft	Active	No
GW, Well 6	Mt Simon	161435	1985	1,650	817 ft	Active	Yes
GW, Well 7	Glacial Drift	557822	1996	1,750	368 ft	Active	No
GW, Well 8	Tunnel City/Wonewoc	674318	2003	1,000	576 ft	Active	Yes
GW, Well 9	Jordan	677176	2003	870	333 ft	Active	Yes
Interconnection	City of Chanhassen	-		1,400 GPM	-	Emergency	NA
Interconnection	City of Victoria	-		1,200 GPM	-	Emergency	NA

Limits on Emergency Interconnections

Discuss any limitations on the use of the water sources (e.g. not to be operated simultaneously, limitations due to blending, aquifer recovery issues etc.) and the use of interconnections, including capacity limits or timing constraints (i.e. only 200 gallons per minute are available from the City of Prior Lake, and it is estimated to take 6 hours to establish the emergency connection). If there are no limitations, list none.

Both Chaska and the adjacent utility (Chanhassen or Victoria) need to open a closed valve to allow for emergency interconnection. Closed valves are exercised and interconnection pipes flushed annually.

D. Future Demand Projections – Key Metropolitan Council Benchmark

Water Use Trends

Use the data in Table 2 to describe trends in 1) population served; 2) total per capita water demand; 3) average daily demand; 4) maximum daily demand. Then explain the causes for upward or downward trends. For example, over the ten years has the average daily demand trended up or down? Why is this occurring?

Population growth in Chaska is approximately 1.2% annually since 2011, down from a peak of 5% in 2008.

Total per capita water demand is decreasing; from over 150 gpcd in 2005 – 2007 to 113 gpcd in 2014 – 2015. The total per capita water demand average was approximately 130 gpcd between 2007 and 2015.

Average day water demand has been relatively flat over the last 10 years as per capita water usage has dropped as population has slowly increased. However, the maximum day water demands have decreased from a high of 8.37 MGD in 2006 to 6.01 MGD in 2015.

Use the water use trend information discussed above to complete Table 7 with projected annual demand for the next ten years. Communities in the seven-county Twin Cities metropolitan area must also include projections for 2030 and 2040 as part of their local comprehensive planning.

Projected demand should be consistent with trends evident in the historical data in Table 2, as discussed above. Projected demand should also reflect state demographer population projections and/or other planning projections.

Table 7. Projected annual water demand

Year	Projected Total Population	Projected Population Served	Projected Total Per Capita Water Demand (GPCD)	Projected Average Daily Demand (MGD)	Projected Maximum Daily Demand (MGD)
2016	26,000	25,300	130	3.3	8.2
2017	26,275	25,563	130	3.3	8.3
2018	26,550	25,827	130	3.4	8.4
2019	26,825	26,090	130	3.4	8.5
2020	27,100	26,353	130	3.4	8.6
2021	27,590	26,843	130	3.5	8.7
2022	28,080	27,333	130	3.6	8.9
2023	28,570	27,823	130	3.6	9.0
2024	29,060	28,313	130	3.7	9.2
2025	29,550	28,803	130	3.7	9.4
2030	32,000	31,253	130	4.1	10.2
2040	36,600	35,853	130	4.7	11.7

GPCD – Gallons per Capita per Day

MGD – Million Gallons per Day

Projection Method

Describe the method used to project water demand, including assumptions for population and business growth and how water conservation and efficiency programs affect projected water demand:

The total per capita water demand average was approximately 130 gpcd between 2007 and 2015. This per capita is projected forward through 2040 as population growth in Chaska increases over 40 percent. Chaska has experienced a significant drop in per capita water use since the previous water supply plan.

The projected maximum day demand was calculated based on a maximum to average day demand ratio of 2.5. The last several years the maximum day demand ratio has been lower, but for planning purposes a conservative approach is preferred. A maximum day demand factor of 2.5 has not been exceeded since 2006.

E. Resource Sustainability

Monitoring – Key DNR Benchmark

Complete Table 8 by inserting information about source water quality monitoring efforts. The list should include all production wells, observation wells, and source water intakes or reservoirs. Additional information on groundwater level monitoring program at: http://www.dnr.state.mn.us/waters/groundwater_section/obwell/index.html

Table 8. Information about source water quality monitoring

MN Unique Well # or Surface Water ID	Type of monitoring point	Monitoring program	Frequency of monitoring	Monitoring Method
200809 Well 4	<input checked="" type="checkbox"/> production well <input type="checkbox"/> observation well <input type="checkbox"/> source water intake <input type="checkbox"/> source water reservoir	<input type="checkbox"/> Routine MDH sampling <input checked="" type="checkbox"/> Routine water utility sampling <input type="checkbox"/> other	<input checked="" type="checkbox"/> continuous <input type="checkbox"/> hourly <input type="checkbox"/> daily <input type="checkbox"/> monthly <input type="checkbox"/> quarterly <input type="checkbox"/> annually	<input checked="" type="checkbox"/> SCADA <input type="checkbox"/> grab sampling <input type="checkbox"/> steel tape <input type="checkbox"/> stream gauge

MN Unique Well # or Surface Water ID	Type of monitoring point	Monitoring program	Frequency of monitoring	Monitoring Method
110453 Well 5	<input checked="" type="checkbox"/> production well <input type="checkbox"/> observation well <input type="checkbox"/> source water intake <input type="checkbox"/> source water reservoir	<input type="checkbox"/> Routine MDH sampling <input checked="" type="checkbox"/> Routine water utility sampling <input type="checkbox"/> other	<input checked="" type="checkbox"/> continuous <input type="checkbox"/> hourly <input type="checkbox"/> daily <input type="checkbox"/> monthly <input type="checkbox"/> quarterly <input type="checkbox"/> annually	<input checked="" type="checkbox"/> SCADA <input type="checkbox"/> grab sampling <input type="checkbox"/> steel tape <input type="checkbox"/> stream gauge
161435 Well 6	<input checked="" type="checkbox"/> production well <input type="checkbox"/> observation well <input type="checkbox"/> source water intake <input type="checkbox"/> source water reservoir	<input type="checkbox"/> Routine MDH sampling <input checked="" type="checkbox"/> Routine water utility sampling <input type="checkbox"/> other	<input checked="" type="checkbox"/> continuous <input type="checkbox"/> hourly <input type="checkbox"/> daily <input type="checkbox"/> monthly <input type="checkbox"/> quarterly <input type="checkbox"/> annually	<input checked="" type="checkbox"/> SCADA <input type="checkbox"/> grab sampling <input type="checkbox"/> steel tape <input type="checkbox"/> stream gauge
557822 Well 7	<input checked="" type="checkbox"/> production well <input type="checkbox"/> observation well <input type="checkbox"/> source water intake <input type="checkbox"/> source water reservoir	<input type="checkbox"/> Routine MDH sampling <input checked="" type="checkbox"/> Routine water utility sampling <input type="checkbox"/> other	<input checked="" type="checkbox"/> continuous <input type="checkbox"/> hourly <input type="checkbox"/> daily <input type="checkbox"/> monthly <input type="checkbox"/> quarterly <input type="checkbox"/> annually	<input checked="" type="checkbox"/> SCADA <input type="checkbox"/> grab sampling <input type="checkbox"/> steel tape <input type="checkbox"/> stream gauge
674318 Well 8	<input checked="" type="checkbox"/> production well <input type="checkbox"/> observation well <input type="checkbox"/> source water intake <input type="checkbox"/> source water reservoir	<input type="checkbox"/> Routine MDH sampling <input checked="" type="checkbox"/> Routine water utility sampling <input type="checkbox"/> other	<input checked="" type="checkbox"/> continuous <input type="checkbox"/> hourly <input type="checkbox"/> daily <input type="checkbox"/> monthly <input type="checkbox"/> quarterly <input type="checkbox"/> annually	<input checked="" type="checkbox"/> SCADA <input type="checkbox"/> grab sampling <input type="checkbox"/> steel tape <input type="checkbox"/> stream gauge
677176 Well 9	<input checked="" type="checkbox"/> production well <input type="checkbox"/> observation well <input type="checkbox"/> source water intake <input type="checkbox"/> source water reservoir	<input type="checkbox"/> Routine MDH sampling <input checked="" type="checkbox"/> Routine water utility sampling <input type="checkbox"/> other	<input checked="" type="checkbox"/> continuous <input type="checkbox"/> hourly <input type="checkbox"/> daily <input type="checkbox"/> monthly <input type="checkbox"/> quarterly <input type="checkbox"/> annually	<input checked="" type="checkbox"/> SCADA <input type="checkbox"/> grab sampling <input type="checkbox"/> steel tape <input type="checkbox"/> stream gauge

Water Level Data

A water level monitoring plan that includes monitoring locations and a schedule for water level readings must be submitted as **Appendix 2**. If one does not already exist, it needs to be prepared and submitted with the WSP. Ideally, all production and observation wells are monitored at least monthly.

Complete Table 9 to summarize water level data for each well being monitored. Provide the name of the aquifer and a brief description of how much water levels vary over the season (the difference between the highest and lowest water levels measured during the year) and the long-term trends for each well. If water levels are not measured and recorded on a routine basis, then provide the static water level when each well was constructed and the most recent water level measured during the same season the well was constructed. Also include all water level data taken during any well and pump maintenance. Add rows to the table as needed.

Provide water level data graphs for each well in **Appendix 3** for the life of the well, or for as many years as water levels have been measured. See DNR website for Date Time Water Level http://www.dnr.state.mn.us/waters/groundwater_section/obwell/waterleveldata.html

Table 9. Water level data

Unique Well Number or Well ID	Aquifer Name	Seasonal Variation (Feet)	Long-term Trend in water level data	Water level measured during well/pumping maintenance
200809 Well 4	Mt Simon/Hinckley	~50 ft	<input type="checkbox"/> Falling <input type="checkbox"/> Stable <input checked="" type="checkbox"/> Rising	08/2016: 211 ft 08/2015: 226 ft 08/2014: 231 ft
110453 Well 5	Mt Simon/Hinckley	~55 ft	<input checked="" type="checkbox"/> Falling <input type="checkbox"/> Stable <input type="checkbox"/> Rising	08/2016: 230 ft 08/2015: 228 ft 08/2014: 228 ft
161435 Well 6	Mt Simon/Hinckley	~60 ft	<input type="checkbox"/> Falling <input type="checkbox"/> Stable <input checked="" type="checkbox"/> Rising	08/2016: 235 ft 08/2015: 226 ft 08/2014: 236 ft
557822 Well 7	Glacial Drift	~0 ft	<input type="checkbox"/> Falling <input type="checkbox"/> Stable <input checked="" type="checkbox"/> Rising	08/2016: 178 ft 08/2015: 178 ft 08/2014: 178 ft
674318 Well 8	FIG	~25 ft	<input type="checkbox"/> Falling <input checked="" type="checkbox"/> Stable <input type="checkbox"/> Rising	08/2016: 148 ft 08/2015: 148 ft 08/2014: 151 ft
677176 Well 9	Jordan	~10 ft	<input type="checkbox"/> Falling <input checked="" type="checkbox"/> Stable <input type="checkbox"/> Rising	08/2016: 125 ft 08/2015: 124 ft 08/2014: 125 ft

Potential Water Supply Issues & Natural Resource Impacts – Key DNR & Metropolitan Council Benchmark

Complete Table 10 by listing the types of natural resources that are or could be impacted by permitted water withdrawals. If known, provide the name of specific resources that may be impacted. Identify what the greatest risks to the resource are and how the risks are being assessed. Identify any resource protection thresholds – formal or informal – that have been established to identify when actions should be taken to mitigate impacts. Provide information about the potential mitigation actions that may be taken, if a resource protection threshold is crossed. Add additional rows to the table as needed. See the glossary at the end of the template for definitions.

Some of this baseline data should have been in your earlier water supply plans or county comprehensive water plans. When filling out this table, think of what are the water supply risks, identify the resources, determine the threshold and then determine what your community will do to mitigate the impacts.

Your DNR area hydrologist is available to assist with this table.

For communities in the seven-county Twin Cities metropolitan area, the *Master Water Supply Plan Appendix 1 (Water Supply Profiles)*, provides information about potential water supply issues and natural resource impacts for your community.

Table 10. Natural resource impacts

Resource Type	Resource Name	Risk	Risk Assessed Through	Describe Resource Protection Threshold*	Mitigation Measure or Management Plan	Describe How Changes to Thresholds are Monitored
<input type="checkbox"/> River or stream		<input type="checkbox"/> Flow/water level decline <input type="checkbox"/> Degrading water quality trends and/or MCLs exceeded <input type="checkbox"/> Impacts on endangered, threatened, or special concern species habitat or other natural resource impacts <input type="checkbox"/> Other: _____	<input type="checkbox"/> GIS analysis <input type="checkbox"/> Modeling <input type="checkbox"/> Mapping <input type="checkbox"/> Monitoring <input type="checkbox"/> Aquifer testing <input type="checkbox"/> Other: ____		<input type="checkbox"/> Revise permit <input type="checkbox"/> Change groundwater pumping <input type="checkbox"/> Increase conservation <input type="checkbox"/> Other	
<input checked="" type="checkbox"/> Calcareous fen	Seminary Fen	<input checked="" type="checkbox"/> Flow/water level decline <input type="checkbox"/> Degrading water quality trends and/or MCLs exceeded <input checked="" type="checkbox"/> Impacts on endangered, threatened, or special concern species habitat or other natural resource impacts <input type="checkbox"/> Other: _____	<input type="checkbox"/> GIS analysis <input type="checkbox"/> Modeling <input type="checkbox"/> Mapping <input checked="" type="checkbox"/> Monitoring <input type="checkbox"/> Aquifer testing <input type="checkbox"/> Other: ____	Wetlands Conservation Act states that calcareous fens may not be filled, drained, or otherwise degraded (wholly or partially). A measurable decline in water level may constitute draining or degradation.	<input type="checkbox"/> Revise permit <input checked="" type="checkbox"/> Change groundwater pumping <input checked="" type="checkbox"/> Increase conservation <input type="checkbox"/> Other	The DNR establishes the monitoring requirements for permitted water suppliers, determining the threshold at which the fen has been impacted.
<input type="checkbox"/> Lake		<input type="checkbox"/> Flow/water level decline <input type="checkbox"/> Degrading water quality trends and/or MCLs exceeded <input type="checkbox"/> Impacts on endangered, threatened, or special concern species habitat or other natural resource impacts <input type="checkbox"/> Other: _____	<input type="checkbox"/> GIS analysis <input type="checkbox"/> GIS analysis <input type="checkbox"/> Modeling <input type="checkbox"/> Mapping <input type="checkbox"/> Monitoring <input type="checkbox"/> Aquifer testing <input type="checkbox"/> Other: ____		<input type="checkbox"/> Revise permit <input type="checkbox"/> Change groundwater pumping <input type="checkbox"/> Increase conservation <input type="checkbox"/> Other	

Resource Type	Resource Name	Risk	Risk Assessed Through	Describe Resource Protection Threshold*	Mitigation Measure or Management Plan	Describe How Changes to Thresholds are Monitored
<input type="checkbox"/> Wetland		<input type="checkbox"/> Flow/water level decline <input type="checkbox"/> Degrading water quality trends and/or MCLs exceeded <input type="checkbox"/> Impacts on endangered, threatened, or special concern species habitat or other natural resource impacts <input type="checkbox"/> Other: _____	<input type="checkbox"/> GIS analysis <input type="checkbox"/> Modeling <input type="checkbox"/> Mapping <input type="checkbox"/> Monitoring <input type="checkbox"/> Aquifer testing <input type="checkbox"/> Other: ____		<input type="checkbox"/> Revise permit <input type="checkbox"/> Change groundwater pumping <input type="checkbox"/> Increase conservation <input type="checkbox"/> Other	
<input checked="" type="checkbox"/> Trout Stream	Assumption Creek	<input checked="" type="checkbox"/> Flow/water level decline <input type="checkbox"/> Degrading water quality trends and/or MCLs exceeded <input checked="" type="checkbox"/> Impacts on endangered, threatened, or special concern species habitat or other natural resource impacts <input type="checkbox"/> Other: _____	<input type="checkbox"/> GIS analysis <input type="checkbox"/> Modeling <input type="checkbox"/> Mapping <input checked="" type="checkbox"/> Monitoring <input type="checkbox"/> Aquifer testing <input type="checkbox"/> Other: ____	Preserve the seasonal variability of the natural hydrology and maintain geomorphology, water quality, connectivity, and biology of the system the vast majority of the time.	<input type="checkbox"/> Revise permit <input checked="" type="checkbox"/> Change groundwater pumping <input checked="" type="checkbox"/> Increase conservation <input type="checkbox"/> Other	DNR Fisheries makes recommendations to establish thresholds for trout streams. Current threshold is that any impacts resulting in 10% reduction of base flow are unacceptable.
<input checked="" type="checkbox"/> Aquifer	Jordan Aquifer	<input checked="" type="checkbox"/> Flow/water level decline <input type="checkbox"/> Degrading water quality trends and/or MCLs exceeded <input type="checkbox"/> Impacts on endangered, threatened, or special concern species habitat or other natural resource impacts <input type="checkbox"/> Other: _____	<input type="checkbox"/> GIS analysis <input type="checkbox"/> Modeling <input type="checkbox"/> Mapping <input checked="" type="checkbox"/> Monitoring <input checked="" type="checkbox"/> Aquifer testing <input type="checkbox"/> Other: ____	Established threshold guideline is water level drop no more than half of the available head. Law does not allow aquifer to be pumped so that a confined aquifer becomes unconfined.	<input type="checkbox"/> Revise permit <input checked="" type="checkbox"/> Change groundwater pumping <input checked="" type="checkbox"/> Increase conservation <input type="checkbox"/> Other	DNR has oversight on thresholds (and permitting) for pumping from regional bedrock aquifers.

Resource Type	Resource Name	Risk	Risk Assessed Through	Describe Resource Protection Threshold*	Mitigation Measure or Management Plan	Describe How Changes to Thresholds are Monitored
<input type="checkbox"/> Endangered, threatened, or special concern species habitat, other Natural resource impacts						

* Examples of thresholds: a lower limit on acceptable flow in a river or stream; water quality outside of an accepted range; a lower limit on acceptable aquifer level decline at one or more monitoring wells; withdrawals that exceed some percent of the total amount available from a source; or a lower limit on acceptable changes to a protected habitat.

Wellhead Protection (WHP) and Source Water Protection (SWP) Plans

Complete Table 11 to provide status information about WHP and SWP plans.

The emergency procedures in this plan are intended to comply with the contingency plan provisions required in the Minnesota Department of Health’s (MDH) Wellhead Protection (WHP) Plan and Surface Water Protection (SWP) Plan.

Table 11. Status of Wellhead Protection and Source Water Protection Plans

Plan Type	Status	Date Adopted	Date for Update
WHP	<input type="checkbox"/> In Process <input checked="" type="checkbox"/> Completed <input type="checkbox"/> Not Applicable	2006 (Original plan)	2017 (Updated plan in progress)
SWP	<input type="checkbox"/> In Process <input type="checkbox"/> Completed <input checked="" type="checkbox"/> Not Applicable	N/A	N/A

WHP – Wellhead Protection Plan **SWP** – Source Water Protection Plan

F. Capital Improvement Plan (CIP)

Please note that any wells that received approval under a ten-year permit, but that were not built, are now expired and must submit a water appropriations permit.

Adequacy of Water Supply System

Complete Table 12 with information about the adequacy of wells and/or intakes, storage facilities, treatment facilities, and distribution systems to sustain current and projected demands. List planned capital improvements for any system components, in chronological order. Communities in the seven-county Twin Cities metropolitan area should also include information about plans through 2040.

The assessment can be the general status by category; it is not necessary to identify every single well, storage facility, treatment facility, lift station, and mile of pipe.

Please attach your latest Capital Improvement Plan as **Appendix 4**.

Table 12. Adequacy of Water Supply System

System Component	Planned action	Anticipated Construction Year	Notes
Wells/Intakes	<input type="checkbox"/> No action planned - adequate <input type="checkbox"/> Repair/replacement <input checked="" type="checkbox"/> Expansion/addition	2020	Additional water supply well planned
Water Storage Facilities	<input type="checkbox"/> No action planned - adequate <input type="checkbox"/> Repair/replacement <input checked="" type="checkbox"/> Expansion/addition	2025	Future Southwest Water Tower
Water Treatment Facilities	<input type="checkbox"/> No action planned - adequate <input type="checkbox"/> Repair/replacement <input checked="" type="checkbox"/> Expansion/addition	2020	Future Pioneer Trail Water Treatment Plant
Distribution Systems (pipes, valves, etc.)	<input type="checkbox"/> No action planned - adequate <input checked="" type="checkbox"/> Repair/replacement <input type="checkbox"/> Expansion/addition	Ongoing	Continued pipe replacement program and preventative maintenance
Pressure Zones	<input type="checkbox"/> No action planned - adequate <input type="checkbox"/> Repair/replacement <input checked="" type="checkbox"/> Expansion/addition	2030 2030	Future expansion of Golf Course Booster Station serving Zone IV. Connect two separate zones into one zone.
Other:	<input type="checkbox"/> No action planned - adequate <input type="checkbox"/> Repair/replacement <input type="checkbox"/> Expansion/addition		

Proposed Future Water Sources

Complete Table 13 to identify new water source installation planned over the next ten years. Add rows to the table as needed.

Table 13. Proposed future installations/sources

Source	Installation Location (approximate)	Resource Name	Proposed Pumping Capacity (gpm)	Planned Installation Year	Planned Partnerships
Groundwater	Near Well No. 7	Well No. 10	1,000	2020	None
Surface Water	NA				
Interconnection to another supplier	Southwest Chaska	City of Cover water system	Unknown – both systems not yet expanded there.	2040	Carver

Water Source Alternatives - Key Metropolitan Council Benchmark

Do you anticipate the need for alternative water sources in the next 10 years? Yes No

For metro communities, will you need alternative water sources by the year 2040? Yes No

If you answered yes for either question, then complete table 14. If no, insert NA.

Complete Table 14 by checking the box next to alternative approaches that your community is considering, including approximate locations (if known), the estimated amount of future demand that could be met through the approach, the estimated timeframe to implement the approach, potential partnerships, and the major benefits and challenges of the approach. Add rows to the table as needed.

For communities in the seven-county Twin Cities metropolitan area, these alternatives should include approaches the community is considering to meet projected 2040 water demand.

Table 14. Alternative water sources

Alternative Source Considered	Source and/or Installation Location (approximate)	Estimated Amount of Future Demand (%)	Timeframe to Implement (YYYY)	Potential Partners	Benefits	Challenges
<input type="checkbox"/> Groundwater	NA					
<input type="checkbox"/> Surface Water	NA					
<input type="checkbox"/> Reclaimed Stormwater	NA					
<input type="checkbox"/> Reclaimed Wastewater	NA					
<input type="checkbox"/> Interconnection to another supplier	NA					

PART 2. EMERGENCY PREPAREDNESS PROCEDURES

The emergency preparedness procedures outlined in this plan are intended to comply with the contingency plan provisions required by MDH in the WHP and SWP. Water emergencies can occur as a result of vandalism, sabotage, accidental contamination, mechanical problems, power failings, drought, flooding, and other natural disasters. The purpose of emergency planning is to develop emergency response procedures and to identify actions needed to improve emergency preparedness. In the case of a municipality, these procedures should be in support of, and part of, an all-hazard emergency operations plan. Municipalities that already have written procedures dealing with water emergencies should review the following information and update existing procedures to address these water supply protection measures.

A. Federal Emergency Response Plan

Section 1433(b) of the Safe Drinking Water Act, (Public Law 107-188, Title IV- Drinking Water Security and Safety) requires community water suppliers serving over 3,300 people to prepare an Emergency Response Plan.

Do you have a federal emergency response plan? Yes No

If yes, what was the date it was certified? January 2005

Complete Table 15 by inserting the noted information regarding your completed Federal Emergency Response Plan.

Table 15. Emergency Preparedness Plan contact information

Emergency Response Plan Role	Contact Person	Contact Phone Number	Contact Email
Emergency Response Lead	Matt Haefner	612-919-4589	mhaefner@chaskamn.com
Alternate Emergency Response Lead	Brad Doerr	612-919-9679	bdoerr@chaskamn.com

B. Operational Contingency Plan

All utilities should have a written operational contingency plan that describes measures to be taken for water supply mainline breaks and other common system failures as well as routine maintenance.

Do you have a written operational contingency plan? Yes No

At a minimum, a water supplier should prepare and maintain an emergency contact list of contractors and suppliers.

C. Emergency Response Procedures

Water suppliers must meet the requirements of MN Rules 4720.5280 . Accordingly, the Minnesota Department of Natural Resources (DNR) requires public water suppliers serving more than 1,000 people to submit Emergency and Conservation Plans. Water emergency and conservation plans that have been approved by the DNR, under provisions of Minnesota Statute 186 and Minnesota Rules, part 6115.0770, will be considered equivalent to an approved WHP contingency plan.

Emergency Telephone List

Prepare and attach a list of emergency contacts, including the MN Duty Officer (1-800-422-0798), as **Appendix 5**. A template is available at www.mndnr.gov/watersupplyplans

The list should include key utility and community personnel, contacts in adjacent water suppliers, and appropriate local, state and federal emergency contacts. Please be sure to verify and update the contacts on the emergency telephone list and date it. Thereafter, update on a regular basis (once a year is recommended). In the case of a municipality, this information should be contained in a notification and warning standard operating procedure maintained by the Emergency Manager for that community. Responsibilities and services for each contact should be defined.

Current Water Sources and Service Area

Quick access to concise and detailed information on water sources, water treatment, and the distribution system may be needed in an emergency. System operation and maintenance records should be maintained in secured central and back-up locations so that the records are accessible for emergency purposes. A detailed map of the system showing the treatment plants, water sources, storage facilities, supply lines, interconnections, and other information that would be useful in an emergency should also be readily available. It is critical that public water supplier representatives and emergency response personnel communicate about the response procedures and be able to easily obtain this kind of information both in electronic and hard copy formats (in case of a power outage).

Do records and maps exist? Yes No

Can staff access records and maps from a central secured location in the event of an emergency?
 Yes No

Does the appropriate staff know where the materials are located? Yes No

Procedure for Augmenting Water Supplies

Complete Tables 16 – 17 by listing all available sources of water that can be used to augment or replace existing sources in an emergency. Add rows to the tables as needed.

In the case of a municipality, this information should be contained in a notification and warning standard operating procedure maintained by the warning point for that community. Municipalities are encouraged to execute cooperative agreements for potential emergency water services and copies should be included in **Appendix 6**. Outstate Communities may consider using nearby high capacity wells (industry, golf course) as emergency water sources.

WSP should include information on any physical or chemical problems that may limit interconnections to other sources of water. Approvals from the MDH are required for interconnections or the reuse of water.

Table 16. Interconnections with other water supply systems to supply water in an emergency

Other Water Supply System Owner	Capacity (GPM & MGD)	Note Any Limitations On Use	List of services, equipment, supplies available to respond
Chanhasen	1,400 GPM	None, both communities just open valve.	
Victoria	1,200 GPM	None, both communities just open valve.	

GPM – Gallons per minute MGD – million gallons per day

Table 17. Utilizing surface water as an alternative source

Surface Water Source Name	Capacity (GPM)	Capacity (MGD)	Treatment Needs	Note Any Limitations On Use
None				

If not covered above, describe additional emergency measures for providing water (obtaining bottled water, or steps to obtain National Guard services, etc.)

Allocation and Demand Reduction Procedures

Complete Table 18 by adding information about how decisions will be made to allocate water and reduce demand during an emergency. Provide information for each customer category, including its priority ranking, average day demand, and demand reduction potential for each customer category. Modify the customer categories as needed, and add additional lines if necessary.

Water use categories should be prioritized in a way that is consistent with Minnesota Statutes 103G.261 (#1 is highest priority) as follows:

1. Water use for human needs such as cooking, cleaning, drinking, washing and waste disposal; use for on-farm livestock watering; and use for power production that meets contingency requirements.
2. Water use involving consumption of less than 10,000 gallons per day (usually from private wells or surface water intakes)
3. Water use for agricultural irrigation and processing of agricultural products involving consumption of more than 10,000 gallons per day (usually from private high-capacity wells or surface water intakes)
4. Water use for power production above the use provided for in the contingency plan.
5. All other water use involving consumption of more than 10,000 gallons per day.
6. Nonessential uses – car washes, golf courses, etc.

Water used for human needs at hospitals, nursing homes and similar types of facilities should be designated as a high priority to be maintained in an emergency. Lower priority uses will need to address

water used for human needs at other types of facilities such as hotels, office buildings, and manufacturing plants. The volume of water and other types of water uses at these facilities must be carefully considered. After reviewing the data, common sense should dictate local allocation priorities to protect domestic requirements over certain types of economic needs. Water use for lawn sprinkling, vehicle washing, golf courses, and recreation are legislatively considered non-essential.

Table 18. Water use priorities

Customer Category	Allocation Priority	Average Daily Demand (GPD)	Short-Term Emergency Demand Reduction Potential (GPD)
Residential	1	1,350,000	675,000
Commercial/Industrial/Institutional	2	1,115,000	400,000
Commercial/Industrial	5	385,000	105,000
Public	6	42,000	20,000
TOTAL	NA	3,000,000	1,200,000

GPD – Gallons per Day

Tip: Calculating Emergency Demand Reduction Potential

The emergency demand reduction potential for all uses will typically equal the difference between maximum use (summer demand) and base use (winter demand). In extreme emergency situations, lower priority water uses must be restricted or eliminated to protect priority domestic water requirements. Emergency demand reduction potential should be based on average day demands for customer categories within each priority class. Use the tables in Part 3 on water conservation to help you determine strategies.

Complete Table 19 by selecting the triggers and actions during water supply disruption conditions.

Table 19. Emergency demand reduction conditions, triggers and actions (Select all that may apply and describe)

Emergency Triggers	Short-term Actions	Long-term Actions
<input checked="" type="checkbox"/> Contamination <input checked="" type="checkbox"/> Loss of production <input checked="" type="checkbox"/> Infrastructure failure <input checked="" type="checkbox"/> Executive order by Governor <input type="checkbox"/> Other: _____	<input checked="" type="checkbox"/> Supply augmentation through emergency interconnections. <input checked="" type="checkbox"/> Enforce a critical water deficiency ordinance to penalize lawn watering, vehicle washing, golf course and park irrigation & other nonessential uses. <input type="checkbox"/> Water allocation through____ <input type="checkbox"/> Meet with large water users to discuss their contingency plan.	<input checked="" type="checkbox"/> Supply augmentation through emergency interconnections and temporary water treatment, if needed. <input checked="" type="checkbox"/> Enforce a critical water deficiency ordinance to penalize lawn watering, vehicle washing, golf course and park irrigation & other nonessential uses. <input type="checkbox"/> Water allocation through____ <input checked="" type="checkbox"/> Meet with large water users to discuss their contingency plan.

Notification Procedures

Complete Table 20 by selecting trigger for informing customers regarding conservation requests, water use restrictions, and suspensions; notification frequencies; and partners that may assist in the notification process. Add rows to the table as needed.

Table 20. Plan to inform customers regarding conservation requests, water use restrictions, and suspensions

Notification Trigger(s)	Methods (select all that apply)	Update Frequency	Partners
<input checked="" type="checkbox"/> Short-term demand reduction declared (< 1 year)	<input checked="" type="checkbox"/> Website <input checked="" type="checkbox"/> Email list serve <input checked="" type="checkbox"/> Social media (e.g. Twitter, Facebook) <input type="checkbox"/> Direct customer mailing, <input type="checkbox"/> Press release (TV, radio, newspaper), <input type="checkbox"/> Meeting with large water users (> 10% of total city use) <input type="checkbox"/> Other: _____	<input type="checkbox"/> Daily <input checked="" type="checkbox"/> Weekly <input checked="" type="checkbox"/> Monthly <input checked="" type="checkbox"/> Annually	
<input checked="" type="checkbox"/> Long-term Ongoing demand reduction declared	<input checked="" type="checkbox"/> Website <input checked="" type="checkbox"/> Email list serve <input checked="" type="checkbox"/> Social media (e.g. Twitter, Facebook) <input checked="" type="checkbox"/> Direct customer mailing, <input checked="" type="checkbox"/> Press release (TV, radio, newspaper), <input checked="" type="checkbox"/> Meeting with large water users (> 10% of total city use) <input type="checkbox"/> Other: _____	<input checked="" type="checkbox"/> Daily <input checked="" type="checkbox"/> Weekly <input checked="" type="checkbox"/> Monthly <input checked="" type="checkbox"/> Annually	
<input checked="" type="checkbox"/> Governor’s Critical water deficiency declared	<input checked="" type="checkbox"/> Website <input checked="" type="checkbox"/> Email list serve <input checked="" type="checkbox"/> Social media (e.g. Twitter, Facebook) <input checked="" type="checkbox"/> Direct customer mailing, <input checked="" type="checkbox"/> Press release (TV, radio, newspaper), <input checked="" type="checkbox"/> Meeting with large water users (> 10% of total city use) <input type="checkbox"/> Other: _____	<input checked="" type="checkbox"/> Daily <input checked="" type="checkbox"/> Weekly <input checked="" type="checkbox"/> Monthly <input checked="" type="checkbox"/> Annually	

Enforcement

Prior to a water emergency, municipal water suppliers must adopt regulations that restrict water use and outline the enforcement response plan. The enforcement response plan must outline how conditions will be monitored to know when enforcement actions are triggered, what enforcement tools will be used, who will be responsible for enforcement, and what timelines for corrective actions will be expected.

Affected operations, communications, and enforcement staff must then be trained to rapidly implement those provisions during emergency conditions.

Important Note:

Disregard of critical water deficiency orders, even though total appropriation remains less than permitted, is adequate grounds for immediate modification of a public water supply authority's water use permit (2013 MN Statutes 103G.291)

Does the city have a critical water deficiency restriction/official control in place that includes provisions to restrict water use and enforce the restrictions? (This restriction may be an ordinance, rule, regulation, policy under a council directive, or other official control) Yes No

If yes, attach the official control document to this WSP as Appendix 7.

If no, the municipality must adopt such an official control within 6 months of submitting this WSP and submit it to the DNR as an amendment to this WSP.

Irrespective of whether a critical water deficiency control is in place, does the public water supply utility, city manager, mayor, or emergency manager have standing authority to implement water restrictions?
 Yes No

If yes, cite the regulatory authority reference: Chaska Code of Ordinance: Chapter 25, Section 10
(See Appendix 7)

If no, who has authority to implement water use restrictions in an emergency?

PART 3. WATER CONSERVATION PLAN

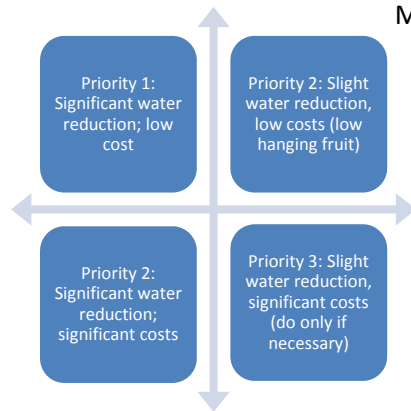

Minnesotans have historically benefited from the state’s abundant water supplies, reducing the need for conservation. There are however, limits to the available supplies of water and increasing threats to the quality of our drinking water. Causes of water supply limitation may include: population increases, economic trends, uneven statewide availability of groundwater, climatic changes, and degraded water quality. Examples of threats to drinking water quality include: the presence of contaminant plumes from past land use activities, exceedances of water quality standards from natural and human sources, contaminants of emerging concern, and increasing pollutant trends from nonpoint sources.

There are many incentives for conserving water; conservation:

- reduces the potential for pumping-induced transfer of contaminants into the deeper aquifers, which can add treatment costs
- reduces the need for capital projects to expand system capacity
- reduces the likelihood of water use conflicts, like well interference, aquatic habitat loss, and declining lake levels
- conserves energy, because less energy is needed to extract, treat and distribute water (and less energy production also conserves water since water is used to produce energy)
- maintains water supplies that can then be available during times of drought

It is therefore imperative that water suppliers implement water conservation plans. The first step in water conservation is identifying opportunities for behavioral or engineering changes that could be made to reduce water use by conducting a thorough analysis of:

- Water use by customer
- Extraction, treatment, distribution, and irrigation system efficiencies
- Industrial processing system efficiencies
- Regulatory and barriers to conservation
- Cultural barriers to conservation
- Water reuse opportunities

Once accurate data is compiled, water suppliers can set achievable goals for reducing water use. A successful water conservation plan follows a logical sequence of events. The plan should address both conservation on the supply side (leak detection and repairs, metering), as well as on the demand side (reductions in usage). Implementation should be conducted in phases, starting with the most obvious and lowest-cost options. In some cases one of the early steps will be reviewing regulatory constraints to water conservation, such as lawn irrigation requirements. Outside funding and grants may be available for implementation of projects. Engage water system operators and maintenance staff and customers in brainstorming opportunities to reduce water use. Ask the question: “How can I help save water?”

Progress since 2006

Is this your community’s first Water Supply Plan? Yes No

If yes, describe conservation practices that you are already implementing, such as: pricing, system improvements, education, regulation, appliance retrofitting, enforcement, etc.

If no, complete Table 21 to summarize conservation actions taken since the adoption of the 2006 water supply plan.

Table 21. Implementation of previous ten-year Conservation Plan

2006 Plan Commitments	Action Taken?
Change Water Rates Structure to provide conservation pricing	<input checked="" type="checkbox"/> Yes <input type="checkbox"/> No
Water Supply System Improvements (e.g. leak repairs, valve replacements, etc.)	<input checked="" type="checkbox"/> Yes <input type="checkbox"/> No
Educational Efforts	<input checked="" type="checkbox"/> Yes <input type="checkbox"/> No
New water conservation ordinances - Prohibited drilling of new private well within MUSA.	<input checked="" type="checkbox"/> Yes <input type="checkbox"/> No
Rebate or retrofitting Program (e.g. for toilet, faucets, appliances, showerheads, dish washers, washing machines, irrigation systems, rain barrels, water softeners, etc.	<input type="checkbox"/> Yes <input checked="" type="checkbox"/> No
Enforcement	<input checked="" type="checkbox"/> Yes <input type="checkbox"/> No
Other – AMI leak detection program for customers	<input checked="" type="checkbox"/> Yes <input type="checkbox"/> No

What are the results you have seen from the actions in Table 21 and how were results measured?

With new smart water meters and leak detection program, the Utility is able to notify customers the same day when a leak is found. This program has an immediate reduction in per capita water usage. In the 18 months of operation the program has identified 350 connections which the Utility has notified of leak alert and offered to assist the water customer with identification and correction.

Total per capita water demand is decreasing; from over 150 gpcd in 2005 – 2007 to 113 gpcd in 2014 – 2015. Residential per capita water demand is decreasing at a high rate; from over 90 gpcd in 2005 – 2007 to 50 gpcd in 2014 – 2015.

A. Triggers for Allocation and Demand Reduction Actions

Complete table 22 by checking each trigger below, as appropriate, and the actions to be taken at various levels or stages of severity. Add in additional rows to the table as needed.

Table 22. Short and long-term demand reduction conditions, triggers and actions

Objective	Triggers	Actions
Protect Surface Water Flows	<input checked="" type="checkbox"/> Low stream flow conditions <input checked="" type="checkbox"/> Reports of declining wetland and lake levels	<input checked="" type="checkbox"/> Increase promotion of conservation measures <input type="checkbox"/> Other: _____
Short-term demand reduction (less than 1 year)	<input checked="" type="checkbox"/> Extremely high seasonal water demand (more than double winter demand) <input checked="" type="checkbox"/> Loss of treatment capacity <input checked="" type="checkbox"/> Lack of water in storage <input checked="" type="checkbox"/> State drought plan <input checked="" type="checkbox"/> Well interference <input type="checkbox"/> Other: _____	<input checked="" type="checkbox"/> Enforce the critical water deficiency ordinance to restrict or prohibit lawn watering, vehicle washing, golf course and park irrigation & other nonessential uses. <input checked="" type="checkbox"/> Supply augmentation through emergency interconnections. <input type="checkbox"/> Water allocation through _____ <input type="checkbox"/> Meet with large water users to discuss user’s contingency plan.
Long-term demand reduction (>1 year)	<input checked="" type="checkbox"/> Per capita demand increasing <input type="checkbox"/> Total demand increase (higher population or more industry) <input type="checkbox"/> Water level in well(s) below elevation of _____ <input type="checkbox"/> Other: _____	<input checked="" type="checkbox"/> Develop a critical water deficiency ordinance that is or can be quickly adopted to penalize lawn watering, vehicle washing, golf course and park irrigation & other nonessential uses. <input checked="" type="checkbox"/> Meet with large water users to discuss user’s contingency plan. <input checked="" type="checkbox"/> Enhanced monitoring and reporting: audits, meters, billing, etc.
Governor’s “Critical Water Deficiency Order” declared	<input checked="" type="checkbox"/> Determined by State	<input checked="" type="checkbox"/> Enact a water waste ordinance that targets overwatering (causing water to flow off the landscape into streets, parking lots, or similar), watering impervious surfaces (streets, driveways or other hardscape areas), and negligence of known leaks, breaks, or malfunctions.

B. Conservation Objectives and Strategies – Key benchmark for DNR

This section establishes water conservation objectives and strategies for eight major areas of water use.

Objective 1: Reduce Unaccounted (Non-Revenue) Water loss to Less than 10%

The Minnesota Rural Waters Association, the Metropolitan Council and the Department of Natural Resources recommend that all water uses be metered. Metering can help identify high use locations and times, along with leaks within buildings that have multiple meters.

It is difficult to quantify specific unmetered water use such as that associated with firefighting and system flushing or system leaks. Typically, water suppliers subtract metered water use from total water pumped to calculate unaccounted or non-revenue water loss.

Is your ten-year average (2005-2014) unaccounted Water Use in Table 2 higher than 10%? Yes No

What is your leak detection monitoring schedule? (e.g. monitor 1/3rd of the city lines per year)

NA. Leak deduction has not provided a cost effective tool for the City of Chaska; the last leak detection survey did not locate any leaks. Unaccounted for water has average 4.5% since last WSP in 2008.

Water Audits - are intended to identify, quantify and verify water and revenue losses. The volume of unaccounted-for water should be evaluated each billing cycle. The American Water Works Association (AWWA) recommends that ten percent or less of pumped water is unaccounted-for water. Water audit procedures are available from the AWWA and MN Rural Water Association www.mrwa.com . Drinking Water Revolving Loan Funds are available for purchase of new meters when new plants are built.

What is the date of your most recent water audit? __NA__

Frequency of water audits: yearly other _if needed__

Leak detection and survey: every year every other year periodic as needed

Year last leak detection survey completed: _2003 ± (no leaks located)_

If Table 2 shows annual water losses over 10% or an increasing trend over time, describe what actions will be taken to reach the <10% loss objective and within what timeframe

Not applicable. Average percent unmetered is 4.6% since 2010.

Metering -AWWA recommends that every water supplier install meters to account for all water taken into its system, along with all water distributed from its system at each customer’s point of service. An effective metering program relies upon periodic performance testing, repair, maintenance or replacement of all meters. AWWA also recommends that water suppliers conduct regular water audits to ensure accountability. Some cities install separate meters for interior and exterior water use, but some research suggests that this may not result in water conservation.

Complete Table 23 by adding the requested information regarding the number, types, testing and maintenance of customer meters.

Table 23. Information about customer meters

Customer Category	Number of Customers	Number of Metered Connections	Number of Automated Meter Readers	Meter testing intervals (years)	Average age/meter replacement schedule (years)
Residential	6,103	6,103	-	10	3 / 25
Commercial	739	739	-	10	3 / 25
Industrial	98	98	-	10	3 / 25
Public Facilities	45	45	-	10	3 / 25
TOTALS	6,985	6,985	4,000	NA	NA

For unmetered systems, describe any plans to install meters or replace current meters with advanced technology meters. Provide an estimate of the cost to implement the plan and the projected water savings from implementing the plan.

Not applicable.

Table 24. Water source meters

	Number of Meters	Meter testing schedule (years)	Number of Automated Meter Readers	Average age/meter replacement schedule (years)
Water Source (wells/intakes)	6	Every 4 years	6 (through SCADA)	11 / 25
Treatment Plant	2	Annually	2 (through SCADA)	11 / 25

Objective 2: Achieve Less than 75 Residential Gallons per Capita Demand (GPCD)

The 2002 average residential per capita demand in the Twin Cities Metropolitan area was 75 gallons per capita per day.

Is your average 2010-2015 residential per capita water demand in Table 2 more than 75? Yes No

What was your 2005 – 2014 ten-year average residential per capita water demand? 73.5 g/person/day

Describe the water use trend over that timeframe:

Residential per capita water demand has decreased from over 95 gpcd in 2006 & 2007 to ~50 gpcd in 2014 & 2015. The residential per capita water demand average was approximately 55 gpcd between 2010 and 2015.

Complete Table 25 by checking which strategies you will use to continue reducing residential per capita demand and project a likely timeframe for completing each checked strategy (Select all that apply and add rows for additional strategies):

Table 25. Strategies and timeframe to reduce residential per capita demand

Strategy to reduce residential per capita demand	Timeframe for completing work
<input type="checkbox"/> Revise city ordinances/codes to encourage or require water efficient landscaping.	
<input type="checkbox"/> Revise city ordinance/codes to permit water reuse options, especially for non-potable purposes like irrigation, groundwater recharge, and industrial use. Check with plumbing authority to see if internal buildings reuse is permitted	
<input checked="" type="checkbox"/> Revise ordinances to limit irrigation. Describe the restricted irrigation plan: Eliminate day time irrigation (no watering 12 – 4).	2017
<input type="checkbox"/> Revise outdoor irrigation installations codes to require high efficiency systems (e.g. those with soil moisture sensors or programmable watering areas) in new installations or system replacements.	
<input checked="" type="checkbox"/> Make water system infrastructure improvements: Continue preventative maintenance to replace aging infrastructure and proactively replace valves and bolts (which fail first).	Ongoing
<input type="checkbox"/> Offer free or reduced cost water use audits) for residential customers.	
<input type="checkbox"/> Implement a notification system to inform customers when water availability conditions change.	
<input type="checkbox"/> Provide rebates or incentives for installing water efficient appliances and/or fixtures indoors (e.g., low flow toilets, high efficiency dish washers and washing machines, showerhead and faucet aerators, water softeners, etc.)	
<input type="checkbox"/> Provide rebates or incentives to reduce outdoor water use (e.g., turf replacement/reduction, rain gardens, rain barrels, smart irrigation, outdoor	

Strategy to reduce residential per capita demand (water use meters, etc.)	Timeframe for completing work
<input type="checkbox"/> Identify supplemental Water Resources	
<input type="checkbox"/> Conduct audience-appropriate water conservation education and outreach.	
<input checked="" type="checkbox"/> Continue Meter Leak Alert Program: Immediately notify customers of detected leak through automatic meter system.	Ongoing

Objective 3: Achieve at least a 1.5% per year water reduction for Institutional, Industrial, Commercial, and Agricultural GPCD over the next 10 years or a 15% reduction in ten years.

Complete Table 26 by checking which strategies you will use to continue reducing non-residential customer use demand and project a likely timeframe for completing each checked strategy (add rows for additional strategies).

Where possible, substitute recycled water used in one process for reuse in another. (For example, spent rinse water can often be reused in a cooling tower.) Keep in mind the true cost of water is the amount on the water bill PLUS the expenses to heat, cool, treat, pump, and dispose of/discharge the water. Don't just calculate the initial investment. Many conservation retrofits that appear to be prohibitively expensive are actually very cost-effective when amortized over the life of the equipment. Often reducing water use also saves electrical and other utility costs. Note: as of 2015, water reuse, and is not allowed by the state plumbing code, M.R. 4715 (a variance is needed). However, several state agencies are addressing this issue.

Table 26. Strategies and timeframe to reduce institutional, commercial industrial, and agricultural and non-revenue use demand

Strategy to reduce total business, industry, agricultural demand	Timeframe for completing work
<input type="checkbox"/> Conduct a facility water use audit for both indoor and outdoor use, including system components	
<input checked="" type="checkbox"/> Install enhanced meters capable of automated readings to detect spikes in consumption: Existing Meter Leak Alert Program	Ongoing
<input type="checkbox"/> Compare facility water use to related industry benchmarks, if available (e.g., meat processing, dairy, fruit and vegetable, beverage, textiles, paper/pulp, metals, technology, petroleum refining etc.),	
<input type="checkbox"/> Install water conservation fixtures and appliances or change processes to conserve water	
<input checked="" type="checkbox"/> Repair leaking system components: Continue preventative maintenance to replace aging infrastructure and proactively replace valves and bolts.	Ongoing
<input type="checkbox"/> Investigate the reuse of reclaimed water (e.g., stormwater, wastewater effluent, process wastewater, etc.)	
<input type="checkbox"/> Reduce outdoor water use (e.g., turf replacement/reduction, rain gardens, rain barrels, smart irrigation, outdoor water use meters, etc.)	
<input checked="" type="checkbox"/> Train Utility employees to provide conservation education to customers.	Add to Utility training program 2017
<input type="checkbox"/> Implement a notification system to inform non-residential customers when water availability conditions change.	
<input type="checkbox"/> [Rainwater catchment systems intended to supply uses such as water closets, urinals, trap primers for floor drains and floor sinks, industrial processes, water features, vehicle washing facilities, cooling tower makeup, and similar uses shall be approved by the commissioner.	
<input type="checkbox"/> Describe other plans:	

Objective 4: Achieve a Decreasing Trend in Total Per Capita Demand

Include as **Appendix 8** one graph showing total per capita water demand for each customer category (i.e., residential, institutional, commercial, industrial) from 2005-2014 and add the calculated/estimated linear trend for the next 10 years.

Describe the trend for each customer category; explain the reason(s) for the trends, and where trends are increasing.

Per capita water use continues to decline. After an increase in industrial water use in 2010 (due to new industrial customer), per capita commercial and industrial water use is approximately 60 gpcd with a slight downward trend. Residential per capita demand is averaging approximately 55 gpcd and trending downward even after a large decrease from over 90 gpcd in 2005 – 2007. Residential use decreased following implementation of new conservation rates.

Objective 5: Reduce Peak Day Demand so that the Ratio of Average Maximum day to the Average Day is less than 2.6

Is the ratio of average 2005-2014 maximum day demand to average 2005-2014 average day demand reported in Table 2 more than 2.6? Yes No

Calculate a ten year average (2005 – 2014) of the ratio of maximum day demand to average day demand: 2.27

The position of the DNR has been that a peak day/average day ratio that is above 2.6 for in summer indicates that the water being used for irrigation by the residents in a community is too large and that efforts should be made to reduce the peak day use by the community.

It should be noted that by reducing the peak day use, communities can also reduce the amount of infrastructure that is required to meet the peak day use. This infrastructure includes new wells, new water towers which can be costly items.

Objective 6: Implement a Conservation Water Rate Structure and/or a Uniform Rate Structure with a Water Conservation Program

Water Conservation Program

Municipal water suppliers serving over 1,000 people are required to adopt demand reduction measures that include a conservation rate structure, or a uniform rate structure with a conservation program that achieves demand reduction. These measures must achieve demand reduction in ways that reduce water demand, water losses, peak water demands, and nonessential water uses. These measures must be approved before a community may request well construction approval from the Department of Health or before requesting an increase in water appropriations permit volume (*Minnesota Statutes*, section 103G.291, subd. 3 and 4). Rates should be adjusted on a regular basis to ensure that revenue of the system is adequate under reduced demand scenarios. If a municipal water supplier intends to use a Uniform Rate Structure, a community-wide Water Conservation Program that will achieve demand reduction must be provided.

Current Water Rates

Include a copy of the actual rate structure in **Appendix 9** or list current water rates including base/service fees and volume charges below.

Volume included in base rate or service charge: NONE

Frequency of billing: Monthly Bimonthly Quarterly Other: _____

Water Rate Evaluation Frequency: every year every ___ years no schedule

Date of last rate change: January 2016

Table 27. Rate structures for each customer category (Select all that apply and add additional rows as needed)

Customer Category	Conservation Billing Strategies in Use *	Conservation Neutral Billing Strategies in Use **	Non-Conserving Billing Strategies in Use ***
Residential	<input checked="" type="checkbox"/> Monthly Billing <input checked="" type="checkbox"/> Increasing block rates (volume tiered rates) <input type="checkbox"/> Seasonal rates <input type="checkbox"/> Time of Use rates <input checked="" type="checkbox"/> Water bills reported in gallons <input type="checkbox"/> Individualized goal rates <input checked="" type="checkbox"/> Excess Use rates <input type="checkbox"/> Drought surcharge <input type="checkbox"/> Use water bill to provide comparisons <input checked="" type="checkbox"/> Service charge not based on water volume <input type="checkbox"/> Other (describe)	<input type="checkbox"/> Uniform <input checked="" type="checkbox"/> Odd/Even day watering	<input type="checkbox"/> Service charge based on water volume <input type="checkbox"/> Declining block <input type="checkbox"/> Flat <input type="checkbox"/> Other (describe)
Commercial/Industrial/Institutional	<input checked="" type="checkbox"/> Monthly Billing <input checked="" type="checkbox"/> Increasing block rates <input type="checkbox"/> Seasonal rates <input type="checkbox"/> Time of Use rates <input checked="" type="checkbox"/> Bill water use in gallons <input type="checkbox"/> Individualized goal rates <input type="checkbox"/> Excess Use rates <input type="checkbox"/> Drought surcharge <input type="checkbox"/> Use water bill to provide comparisons <input checked="" type="checkbox"/> Service charge not based on water volume <input type="checkbox"/> Other (describe)	<input type="checkbox"/> Uniform	<input type="checkbox"/> Service charge based on water volume <input type="checkbox"/> Declining block <input type="checkbox"/> Flat <input type="checkbox"/> Other (describe)

*** Rate Structures components that may promote water conservation:**

- **Monthly billing:** is encouraged to help people see their water usage so they can consider changing behavior.
- **Increasing block rates (also known as a tiered residential rate structure):** Typically, these have at least three tiers: should have at least three tiers.
 - The first tier is for the winter average water use.
 - The second tier is the year-round average use, which is lower than typical summer use. This rate should be set to cover the full cost of service.
 - The third tier should be above the average annual use and should be priced high enough to encourage conservation, as should any higher tiers. For this to be effective, the difference in block rates should be significant.
- **Seasonal rate:** higher rates in summer to reduce peak demands
- **Time of Use rates:** lower rates for off peak water use

- **Bill water use in gallons:** this allows customers to compare their use to average rates
- **Individualized goal rates:** typically used for industry, business or other large water users to promote water conservation if they keep within agreed upon goals. **Excess Use rates:** if water use goes above an agreed upon amount this higher rate is charged
- **Drought surcharge:** an extra fee is charged for guaranteed water use during drought
- **Use water bill to provide comparisons:** simple graphics comparing individual use over time or compare individual use to others.
- **Service charge or base fee that does not include a water volume** – a base charge or fee to cover universal city expenses that are not customer dependent and/or to provide minimal water at a lower rate (e.g., an amount less than the average residential per capita demand for the water supplier for the last 5 years)
- **Emergency rates** -A community may have a separate conservation rate that only goes into effect when the community or governor declares a drought emergency. These higher rates can help to protect the city budgets during times of significantly less water usage.

****Conservation Neutral****

- **Uniform rate:** rate per unit used is the same regardless of the volume used
- **Odd/even day watering** –This approach reduces peak demand on a daily basis for system operation, but it does not reduce overall water use.

***** Non-Conserving *****

- **Service charge or base fee with water volume:** an amount of water larger than the average residential per capita demand for the water supplier for the last 5 years
- **Declining block rate:** the rate per unit used decreases as water use increases.
- **Flat rate:** one fee regardless of how much water is used (usually unmetered).

Provide justification for any conservation neutral or non-conserving rate structures. If intending to adopt a conservation rate structure, include the timeframe to do so:

While conservation neutral, Odd/Even day watering reduces peak water usage, reducing infrastructure needs required to meet peak demands.

Objective 7: Additional strategies to Reduce Water Use and Support Wellhead Protection Planning

Development and redevelopment projects can provide additional water conservation opportunities, such as the actions listed below. If a Uniform Rate Structure is in place, the water supplier must provide a Water Conservation Program that includes at least two of the actions listed below. Check those actions that you intent to implement within the next 10 years.

Table 28. Additional strategies to Reduce Water Use & Support Wellhead Protection

<input type="checkbox"/>	Participate in the GreenStep Cities Program, including implementation of at least one of the 20 “Best Practices” for water
<input type="checkbox"/>	Prepare a Master Plan for Smart Growth (compact urban growth that avoids sprawl)
<input type="checkbox"/>	Prepare a Comprehensive Open Space Plan (areas for parks, green spaces, natural areas)
<input type="checkbox"/>	Adopt a Water Use Restriction Ordinance (lawn irrigation, car washing, pools, etc.)
<input checked="" type="checkbox"/>	Adopt an Outdoor Lawn Irrigation Ordinance: Eliminate day time watering (proposed).
<input type="checkbox"/>	Adopt a Private well Ordinance (private wells in a city must comply with water restrictions)
<input type="checkbox"/>	Implement a Stormwater Management Program
<input type="checkbox"/>	Adopt Non-Zoning Wetlands Ordinance (can further protect wetlands beyond state/federal laws-for vernal pools, buffer areas, restrictions on filling or alterations)
<input type="checkbox"/>	Adopt a Water Offset Program (primarily for new development or expansion)
<input type="checkbox"/>	Implement a Water Conservation Outreach Program
<input type="checkbox"/>	Hire a Water Conservation Coordinator (part-time)
<input type="checkbox"/>	Implement a Rebate program for water efficient appliances, fixtures, or outdoor water management
<input checked="" type="checkbox"/>	Other: No new private wells within the City urban service area and once municipal water service is available private wells no longer allowed for domestic use (Ordinance 25). Well sealing: Carver County operates a well sealing cost share program that provides up to \$750 to seal abandoned, unsealed wells that meet the eligibility criteria.

Objective 8: Tracking Success: How will you track or measure success through the next ten years?

The City of Chaska will track per capita water demand on a regular basis to confirm the conservation trend and if needed, strength conservation practices.

Tip: The process to monitor demand reduction and/or a rate structure includes:

- a) The DNR District Hydrologist or Groundwater Appropriation Hydrologist will call or visit the community the first 1-3 years after the water supply plan is completed.
- b) They will discuss what activities the community is doing to conserve water and if they feel their actions are successful. The Water Supply Plan, Part 3 tables and responses will guide the discussion. For example, they will discuss efforts to reduce unaccounted for water loss if that is a problem, or go through Tables 33, 34 and 35 to discuss new initiatives.
- c) The city representative and the hydrologist will discuss total per capita water use, residential per capita water use, and business/industry use. They will note trends.
- d) They will also discuss options for improvement and/or collect case studies of success stories to share with other communities. One option may be to change the rate structure, but there are many other paths to successful water conservation.
- e) If appropriate, they will cooperatively develop a simple work plan for the next few years, targeting a couple areas where the city might focus efforts.

C. Regulation

Complete Table 29 by selecting which regulations are used to reduce demand and improve water efficiencies. Add additional rows as needed.

Copies of adopted regulations or proposed restrictions or should be included in **Appendix 10** (a list with hyperlinks is acceptable).

Table 29. Regulations for short-term reductions in demand and long-term improvements in water efficiencies

Regulations Utilized	When is it applied (in effect)?
<input checked="" type="checkbox"/> Rainfall sensors required on landscape irrigation systems MN State Statue 103G.298	<input checked="" type="checkbox"/> Ongoing <input type="checkbox"/> Seasonal <input type="checkbox"/> Only during declared Emergencies
<input checked="" type="checkbox"/> Water efficient plumbing fixtures required 1992 Federal Energy Policy Act	<input checked="" type="checkbox"/> New Development <input checked="" type="checkbox"/> Replacement <input type="checkbox"/> Rebate Programs
<input checked="" type="checkbox"/> Critical/Emergency Water Deficiency ordinance	<input checked="" type="checkbox"/> Only during declared Emergencies
<input checked="" type="checkbox"/> Watering restriction requirements (time of day, allowable days, etc.)	<input checked="" type="checkbox"/> Odd/Even <input type="checkbox"/> 2 days/week <input type="checkbox"/> Only during declared Emergencies
<input type="checkbox"/> Water waste prohibited (for example, having a fine for irrigators spraying on the street)	<input type="checkbox"/> -Ongoing <input type="checkbox"/> Seasonal <input type="checkbox"/> Only during declared Emergencies
<input type="checkbox"/> Limitations on turf areas (requiring lots to have 10% - 25% of the space in natural areas)	<input type="checkbox"/> New Development <input type="checkbox"/> Shoreland/zoning <input type="checkbox"/> Other
<input checked="" type="checkbox"/> Soil preparation requirements (after construction, requiring topsoil to be applied to promote good root growth): Carver County requires a minimum of 6" of topsoil and standards for topsoil borrow.	<input checked="" type="checkbox"/> New Development <input type="checkbox"/> Construction Projects <input type="checkbox"/> Other
<input type="checkbox"/> Tree ratios (requiring a certain number of trees per square foot of lawn)	<input type="checkbox"/> New development <input type="checkbox"/> Shoreland/zoning <input type="checkbox"/> Other
<input type="checkbox"/> Permit to fill swimming pool and/or requiring pools to be covered (to prevent evaporation)	<input type="checkbox"/> Ongoing <input type="checkbox"/> Seasonal <input type="checkbox"/> Only during declared Emergencies
<input type="checkbox"/> Ordinances that permit stormwater irrigation, reuse of water, or other alternative water use (Note: be sure to check current plumbing codes for updates)	<input type="checkbox"/> Describe

D. Retrofitting Programs

Education and incentive programs aimed at replacing inefficient plumbing fixtures and appliances can help reduce per capita water use, as well as energy costs. It is recommended that municipal water suppliers develop a long-term plan to retrofit public buildings with water efficient plumbing fixtures and appliances. Some water suppliers have developed partnerships with organizations having similar conservation goals, such as electric or gas suppliers, to develop cooperative rebate and retrofit programs.

A study by the AWWA Research Foundation (Residential End Uses of Water, 1999) found that the average indoor water use for a non-conserving home is 69.3 gallons per capita per day (gpcd). The average indoor water use in a conserving home is 45.2 gpcd and most of the decrease in water use is related to water efficient plumbing fixtures and appliances that can reduce water, sewer and energy costs. In Minnesota, certain electric and gas providers are required (Minnesota Statute 216B.241) to fund programs that will conserve energy resources and some utilities have distributed water efficient showerheads to customers to help reduce energy demands required to supply hot water.

Retrofitting Programs

Complete Table 30 by checking which water uses are targeted, the outreach methods used, the measures used to identify success, and any participating partners.

Table 30. Retrofitting programs (Select all that apply)

Water Use Targets	Outreach Methods	Partners
<input type="checkbox"/> low flush toilets, <input type="checkbox"/> toilet leak tablets, <input type="checkbox"/> low flow showerheads, <input type="checkbox"/> faucet aerators;	<input type="checkbox"/> Education about <input type="checkbox"/> free distribution of <input type="checkbox"/> rebate for <input type="checkbox"/> other	<input type="checkbox"/> Gas company <input type="checkbox"/> Electric company <input type="checkbox"/> Watershed organization
<input type="checkbox"/> water conserving washing machines, <input type="checkbox"/> dish washers, <input type="checkbox"/> water softeners;	<input type="checkbox"/> Education about <input type="checkbox"/> free distribution of <input type="checkbox"/> rebate for <input type="checkbox"/> other	<input type="checkbox"/> Gas company <input type="checkbox"/> Electric company <input type="checkbox"/> Watershed organization
<input type="checkbox"/> rain gardens, <input type="checkbox"/> rain barrels, <input type="checkbox"/> Native/drought tolerant landscaping, etc.	<input type="checkbox"/> Education about <input type="checkbox"/> free distribution of <input type="checkbox"/> rebate for <input type="checkbox"/> other	<input type="checkbox"/> Gas company <input type="checkbox"/> Electric company <input type="checkbox"/> Watershed organization

Briefly discuss measures of success from the above table (e.g. number of items distributed, dollar value of rebates, gallons of water conserved, etc.):

No retrofitting programs completed to date.

E. Education and Information Programs

Customer education should take place in three different circumstances. First, customers should be provided information on how to conserve water and improve water use efficiencies. Second, information should be provided at appropriate times to address peak demands. Third, emergency notices and educational materials about how to reduce water use should be available for quick distribution during an emergency.

Proposed Education Programs

Complete Table 31 by selecting which methods are used to provide water conservation and information, including the frequency of program components. Select all that apply and add additional lines as needed.

Table 31. Current and Proposed Education Programs

Education Methods	General summary of topics	#/Year	Frequency
Billing inserts or tips printed on the actual bill	Odd/Even Watering requirement; includes fine amount for violations	2	<input type="checkbox"/> Ongoing <input checked="" type="checkbox"/> Seasonal <input type="checkbox"/> During declared emergencies
Consumer Confidence Reports	Odd/Even Watering requirement; includes fine amount for violations	1	<input checked="" type="checkbox"/> Ongoing <input type="checkbox"/> Seasonal <input type="checkbox"/> During declared emergencies
Press releases to traditional local news outlets (e.g., newspapers, radio and TV)	Demand reduction	-	<input type="checkbox"/> Ongoing <input type="checkbox"/> Seasonal <input checked="" type="checkbox"/> During declared emergencies
Social media distribution (e.g., emails, Facebook, Twitter)	Emergency notifications Conservation information	-	<input checked="" type="checkbox"/> Ongoing <input type="checkbox"/> Seasonal <input type="checkbox"/> During declared emergencies
Paid advertisements (e.g., billboards, print media, TV, radio, web sites, etc.)			<input type="checkbox"/> Ongoing <input type="checkbox"/> Seasonal <input type="checkbox"/> During declared emergencies
Presentations to community groups			<input type="checkbox"/> Ongoing <input type="checkbox"/> Seasonal <input type="checkbox"/> During declared emergencies
Staff training	Education on conservation to pass on to customers as needed.	-	<input checked="" type="checkbox"/> Ongoing <input type="checkbox"/> Seasonal <input type="checkbox"/> During declared emergencies
Facility tours	Education and Conservation	2	<input checked="" type="checkbox"/> Ongoing <input type="checkbox"/> Seasonal <input type="checkbox"/> During declared emergencies
Displays and exhibits			<input type="checkbox"/> Ongoing <input type="checkbox"/> Seasonal <input type="checkbox"/> During declared emergencies
Marketing rebate programs (e.g., indoor fixtures & appliances and outdoor practices)			<input type="checkbox"/> Ongoing <input type="checkbox"/> Seasonal <input type="checkbox"/> During declared emergencies
Community news letters			<input type="checkbox"/> Ongoing <input type="checkbox"/> Seasonal <input type="checkbox"/> During declared emergencies
Direct mailings (water audit/retrofit kits, showerheads, brochures)			<input type="checkbox"/> Ongoing <input type="checkbox"/> Seasonal <input type="checkbox"/> During declared emergencies
Information kiosk at utility and public buildings	Conservation	-	<input checked="" type="checkbox"/> Ongoing <input type="checkbox"/> Seasonal <input type="checkbox"/> During declared emergencies
Public Service Announcements			<input type="checkbox"/> Ongoing <input type="checkbox"/> Seasonal <input type="checkbox"/> During declared emergencies
Cable TV Programs			<input type="checkbox"/> Ongoing <input type="checkbox"/> Seasonal <input type="checkbox"/> During declared emergencies
Demonstration projects (landscaping or plumbing)			<input type="checkbox"/> Ongoing <input type="checkbox"/> Seasonal <input type="checkbox"/> During declared emergencies

Education Methods	General summary of topics	#/Year	Frequency
K-12 Education programs (Project Wet, Drinking Water Institute, presentations)			<input type="checkbox"/> Ongoing <input type="checkbox"/> Seasonal <input type="checkbox"/> During declared emergencies
Community Events (children’s water festivals, environmental fairs)			<input type="checkbox"/> Ongoing <input type="checkbox"/> Seasonal <input type="checkbox"/> During declared emergencies
Community education classes			<input type="checkbox"/> Ongoing <input type="checkbox"/> Seasonal <input type="checkbox"/> During declared emergencies
Water Week promotions			<input type="checkbox"/> Ongoing <input type="checkbox"/> Seasonal <input type="checkbox"/> During declared emergencies
Website (include address: ChaskaMN.com)	Leak identification information.	24/7	<input checked="" type="checkbox"/> Ongoing <input type="checkbox"/> Seasonal <input type="checkbox"/> During declared emergencies
Targeted efforts (large volume users, users with large increases)			<input type="checkbox"/> Ongoing <input type="checkbox"/> Seasonal <input type="checkbox"/> During declared emergencies
Notices of ordinances			<input type="checkbox"/> Ongoing <input type="checkbox"/> Seasonal <input type="checkbox"/> During declared emergencies
Emergency conservation notices	Draft documents ahead of time.	-	<input type="checkbox"/> Ongoing <input type="checkbox"/> Seasonal <input checked="" type="checkbox"/> During declared emergencies
Smart Meter Alert Program	Identify leaks and notify customer immediately.	24/7	<input checked="" type="checkbox"/> Ongoing <input type="checkbox"/> Seasonal <input type="checkbox"/> During declared emergencies
Other:			<input type="checkbox"/> Ongoing <input type="checkbox"/> Seasonal <input type="checkbox"/> During declared emergencies

Briefly discuss what future education and information activities your community is considering in the future:

The City of Chaska will increase the amount of social media posts to increase conservation education.

Develop emergency conservation notices ahead of emergency so documents are ready for distribution in an emergency.

Add water conservation information to the City website to make it available to customers all the time.

Bundle conservation materials and have available for when customers request information on conservation or how to reduce their water bill.



PART 4. ITEMS FOR METROPOLITAN AREA COMMUNITIES

Minnesota Statute 473.859 requires WSPs to be completed for all local units of government in the seven-county Metropolitan Area as part of the local comprehensive planning process.

Much of the information in Parts 1-3 addresses water demand for the next 10 years. However, additional information is needed to address water demand through 2040, which will make the WSP consistent with the Metropolitan Land Use Planning Act, upon which the local comprehensive plans are based.

This Part 4 provides guidance to complete the WSP in a way that addresses plans for water supply through 2040.

A. Water Demand Projections through 2040

Complete Table 7 in Part 1D by filling in information about long-term water demand projections through 2040. Total Community Population projections should be consistent with the community's system statement, which can be found on the Metropolitan Council's website and which was sent to the community in September 2015.

Projected Average Day, Maximum Day, and Annual Water Demands may either be calculated using the method outlined in *Appendix 2* of the *2015 Master Water Supply Plan* or by a method developed by the individual water supplier.

B. Potential Water Supply Issues

Complete Table 10 in Part 1E by providing information about the potential water supply issues in your community, including those that might occur due to 2040 projected water use.

The *Master Water Supply Plan* provides information about potential issues for your community in *Appendix 1 (Water Supply Profiles)*. This resource may be useful in completing Table 10.

You may document results of local work done to evaluate impact of planned uses by attaching a feasibility assessment or providing a citation and link to where the plan is available electronically.

C. Proposed Alternative Approaches to Meet Extended Water Demand Projections

Complete Table 12 in Part 1F with information about potential water supply infrastructure impacts (such as replacements, expansions or additions to wells/intakes, water storage and treatment capacity, distribution systems, and emergency interconnections) of extended plans for development and redevelopment, in 10-year increments through 2040. It may be useful to refer to information in the community's local Land Use Plan, if available.

Complete Table 14 in Part 1F by checking each approach your community is considering to meet future demand. For each approach your community is considering, provide information about the amount of future water demand to be met using that approach, the timeframe to implement the approach, potential partners, and current understanding of the key benefits and challenges of the approach.

As challenges are being discussed, consider the need for: evaluation of geologic conditions (mapping, aquifer tests, modeling), identification of areas where domestic wells could be impacted, measurement and analysis of water levels & pumping rates, triggers & associated actions to protect water levels, etc.

D. Value-Added Water Supply Planning Efforts (Optional)

The following information is not required to be completed as part of the local water supply plan, but completing this can help strengthen source water protection throughout the region and help Metropolitan Council and partners in the region to better support local efforts.

Source Water Protection Strategies

Does a Drinking Water Supply Management Area for a neighboring public water supplier overlap your community? Yes No

If you answered no, skip this section. If you answered yes, please complete Table 32 with information about new water demand or land use planning-related local controls that are being considered to provide additional protection in this area.

Table 32. Local controls and schedule to protect Drinking Water Supply Management Areas

Local Control	Schedule to Implement	Potential Partners
<input type="checkbox"/> None at this time		
<input type="checkbox"/> Comprehensive planning that guides development in vulnerable drinking water supply management areas		
<input type="checkbox"/> Zoning overlay		
<input type="checkbox"/> Other:		

Technical assistance

From your community’s perspective, what are the most important topics for the Metropolitan Council to address, guided by the region’s Metropolitan Area Water Supply Advisory Committee and Technical Advisory Committee, as part of its ongoing water supply planning role?

- Coordination of state, regional and local water supply planning roles
- Regional water use goals
- Water use reporting standards
- Regional and sub-regional partnership opportunities
- Identifying and prioritizing data gaps and input for regional and sub-regional analyses
- Others: _____

GLOSSARY

Agricultural/Irrigation Water Use - Water used for crop and non-crop irrigation, livestock watering, chemigation, golf course irrigation, landscape and athletic field irrigation.

Average Daily Demand - The total water pumped during the year divided by 365 days.

Calcareous Fen - Calcareous fens are rare and distinctive wetlands dependent on a constant supply of cold groundwater. Because they are dependent on groundwater and are one of the rarest natural communities in the United States, they are a protected resource in MN. Approximately 200 have been located in Minnesota. They may not be filled, drained or otherwise degraded.

Commercial/Institutional Water Use - Water used by motels, hotels, restaurants, office buildings, commercial facilities and institutions (both civilian and military). Consider maintaining separate institutional water use records for emergency planning and allocation purposes. Water used by multi-family dwellings, apartment buildings, senior housing complexes, and mobile home parks should be reported as Residential Water Use.

Commercial/Institutional/Industrial (C/I/I) Water Sold - The sum of water delivered for commercial/institutional or industrial purposes.

Conservation Rate Structure - A rate structure that encourages conservation and may include increasing block rates, seasonal rates, time of use rates, individualized goal rates, or excess use rates. If a conservation rate is applied to multifamily dwellings, the rate structure must consider each residential unit as an individual user. A community may have a separate conservation rate that only goes into effect when the community or governor declares a drought emergency. These higher rates can help to protect the city budgets during times of significantly less water usage.

Date of Maximum Daily Demand - The date of the maximum (highest) water demand. Typically this is a day in July or August.

Declining Rate Structure - Under a declining block rate structure, a consumer pays less per additional unit of water as usage increases. This rate structure does not promote water conservation.

Distribution System - Water distribution systems consist of an interconnected series of pipes, valves, storage facilities (water tanks, water towers, reservoirs), water purification facilities, pumping stations, flushing hydrants, and components that convey drinking water and meeting fire protection needs for cities, homes, schools, hospitals, businesses, industries and other facilities.

Flat Rate Structure - Flat fee rates do not vary by customer characteristics or water usage. This rate structure does not promote water conservation.

Industrial Water Use - Water used for thermonuclear power (electric utility generation) and other industrial use such as steel, chemical and allied products, paper and allied products, mining, and petroleum refining.

Low Flow Fixtures/Appliances - Plumbing fixtures and appliances that significantly reduce the amount of water released per use are labeled “low flow”. These fixtures and appliances use just enough water to be effective, saving excess, clean drinking water that usually goes down the drain.

Maximum Daily Demand - The maximum (highest) amount of water used in one day.

Metered Residential Connections - The number of residential connections to the water system that have meters. For multifamily dwellings, report each residential unit as an individual user.

Percent Unmetered/Unaccounted For - Unaccounted for water use is the volume of water withdrawn from all sources minus the volume of water delivered. This value represents water “lost” by miscalculated water use due to inaccurate meters, water lost through leaks, or water that is used but unmetered or otherwise undocumented. Water used for public services such as hydrant flushing, ice skating rinks, and public swimming pools should be reported under the category “Water Supplier Services”.

Population Served - The number of people who are served by the community’s public water supply system. This includes the number of people in the community who are connected to the public water supply system, as well as people in neighboring communities who use water supplied by the community’s public water supply system. It should not include residents in the community who have private wells or get their water from neighboring water supply.

Residential Connections - The total number of residential connections to the water system. For multifamily dwellings, report each residential unit as an individual user.

Residential Per Capita Demand - The total residential water delivered during the year divided by the population served divided by 365 days.

Residential Water Use - Water used for normal household purposes such as drinking, food preparation, bathing, washing clothes and dishes, flushing toilets, and watering lawns and gardens. Should include all water delivered to single family private residences, multi-family dwellings, apartment buildings, senior housing complexes, mobile home parks, etc.

Smart Meter - Smart meters can be used by municipalities or by individual homeowners. Smart metering generally indicates the presence of one or more of the following:

- Smart irrigation water meters are controllers that look at factors such as weather, soil, slope, etc. and adjust watering time up or down based on data. Smart controllers in a typical summer will reduce water use by 30%-50%. Just changing the spray nozzle to new efficient models can reduce water use by 40%.
- Smart Meters on customer premises that measure consumption during specific time periods and communicate it to the utility, often on a daily basis.
- A communication channel that permits the utility, at a minimum, to obtain meter reads on demand, to ascertain whether water has recently been flowing through the meter and onto the premises, and to issue commands to the meter to perform specific tasks such as disconnecting or restricting water flow.

Total Connections - The number of connections to the public water supply system.

Total Per Capita Demand - The total amount of water withdrawn from all water supply sources during the year divided by the population served divided by 365 days.

Total Water Pumped - The cumulative amount of water withdrawn from all water supply sources during the year.

Total Water Delivered - The sum of residential, commercial, industrial, institutional, water supplier services, wholesale and other water delivered.

Ultimate (Full Build-Out) - Time period representing the community’s estimated total amount and location of potential development, or when the community is fully built out at the final planned density.

Unaccounted (Non-revenue) Loss - See definitions for “percent unmetered/unaccounted for loss”.

Uniform Rate Structure - A uniform rate structure charges the same price-per-unit for water usage beyond the fixed customer charge, which covers some fixed costs. The rate sends a price signal to the customer because the water bill will vary by usage. Uniform rates by class charge the same price-per-unit for all customers within a customer class (e.g. residential or non-residential). This price structure is generally considered less effective in encouraging water conservation.

Water Supplier Services - Water used for public services such as hydrant flushing, ice skating rinks, public swimming pools, city park irrigation, back-flushing at water treatment facilities, and/or other uses.

Water Used for Nonessential Purposes - Water used for lawn irrigation, golf course and park irrigation, car washes, ornamental fountains, and other non-essential uses.

Wholesale Deliveries - The amount of water delivered in bulk to other public water suppliers.

Acronyms and Initialisms

AWWA – American Water Works Association

C/I/I – Commercial/Institutional/Industrial

CIP – Capital Improvement Plan

GIS – Geographic Information System

GPCD – Gallons per capita per day

GWMA – Groundwater Management Area – North and East Metro, Straight River, Bonanza,

MDH – Minnesota Department of Health

MGD – Million gallons per day

MG – Million gallons

MGL – Maximum Contaminant Level

MnTAP – Minnesota Technical Assistance Program (University of Minnesota)

MPARS – MN/DNR Permitting and Reporting System (new electronic permitting system)

MRWA – Minnesota Rural Waters Association

SWP – Source Water Protection

WHP – Wellhead Protection

APPENDICES TO BE SUBMITTED BY THE WATER SUPPLIER

Appendix 1: Well records and maintenance summaries – see Part 1C

Appendix 2: Water level monitoring plan – see Part 1E

Appendix 3: Water level graphs for each water supply well – see Part 1E

Appendix 4: Capital Improvement Plan – see Part 1E

Appendix 5: Emergency Telephone List – see Part 2C

Appendix 6: Cooperative Agreements for Emergency Services – see Part 2C

Appendix 7: Municipal Critical Water Deficiency Ordinance – see Part 2C

Appendix 8: Graph showing annual per capita water demand for each customer category during the last ten-years – see Part 3 Objective 4

Appendix 9: Water Rate Structure – see Part 3 Objective 6

Appendix 10: Adopted or proposed regulations to reduce demand or improve water efficiency – see Part 3 Objective 7

Appendix 11: Implementation Checklist – summary of all the actions that a community is doing, or proposes to do, including estimated implementation dates

APPENDIX 1: WELL RECORDS AND MAINTENANCE SUMMARIES

WELL DATA:

DRILLER: HYDRO ENGINEERING, INC.
 DRILLING DATE: JUNE 1972
 STATIC WATER LEVEL: 151 FT
 PUMPING LEVEL: 244 FT AT 1800 GPM
 ORIGINAL CASING EL.: 895.44

PUMP DATA

INSTALLER: KEYS WELL DRILLING
 INSTALLATION DATE: JUNE 2006
 CAPACITY: 1800 GPM, 366 FT, 1778 RPM
 POWER: 460 VOLTS 3 PHASE
 2006 STATIC W.L. 282 FT

WELL LOG:

DEPTH IN FEET

0 — CASING EL. 892.0

135 — GRAY CLAY

222 — GRAY CLAY & SAND

292 — YELLOW SANDROCK

312 — PINK & GREEN SANDROCK

322 — GREEN SHALE

347 — PINK & GREEN SANDROCK

500 — LIGHT GREEN SANDROCK & SHALE

580 — WHITE SANDROCK

622 — BROWN & GREEN SHALE

655 — BROWN SANDROCK

671 — SANDROCK & SHALE

805 — LIGHT BROWN SANDROCK

811 — RED SHALE

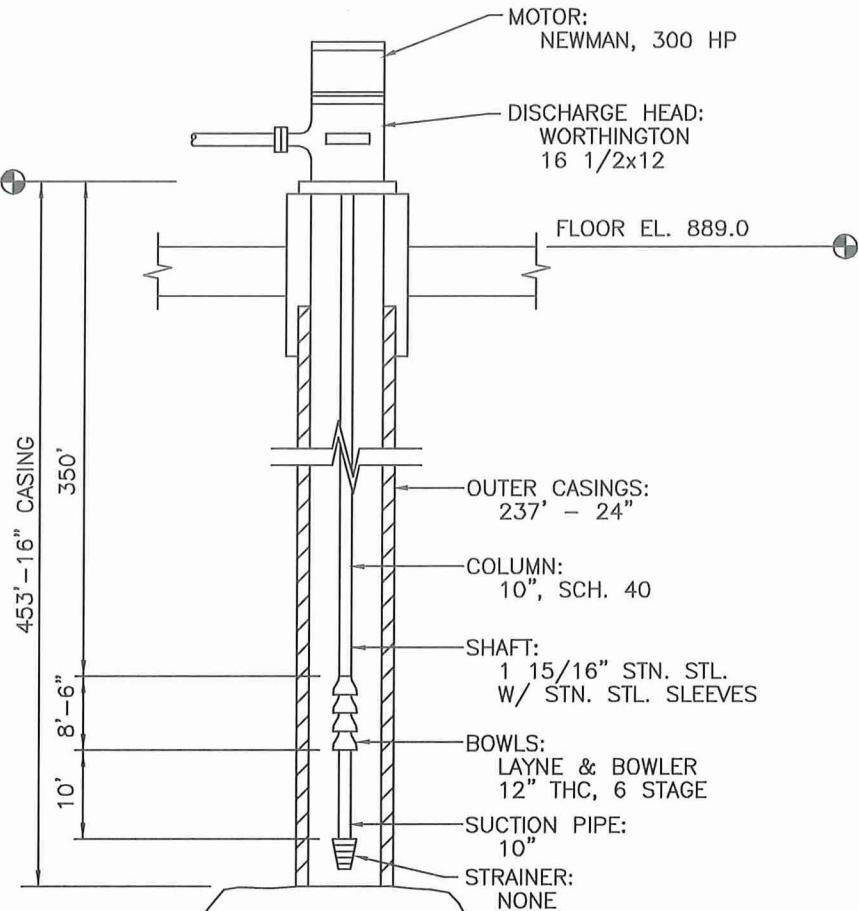

759 CUBIC YARDS REMOVED

BOTTOM HOLE

723'—FEB. 2005
 720'—FEB. 1997
 726'—MAR. 1991
 724'—OCT. 1985
 796'—JULY. 2013

MGS

0-225 DRIFT
 225-295 JOR
 295-325 STL
 325-350 STL-FRN
 350-503 FRN
 503-583 IGL
 583-625 ECR
 625-808 MTS
 808-813 MRC

NOTE:
 SHALE CHUNKS, STOPPED
 BAILING: 730' - 1980
 723' - 2006

2013 BOTTOM 583'
 BEFORE AIR LIFTING 254
 CUBIC YARDS

2013 BOTTOM = 814

9204161BW01.DWG



UNIQUE WELL No.: 200809
 INSTALLED: 1973
 REPAIRED:
 1997—MOST COL, S.S. SHAFT, REPAIR BOWL & MOTOR, LEVEL MONITOR
 2005—235' COLUMN, BOWL REBUILD, BRUSH, TV, BAIL
 2013 - MOTOR REPAIRED, BOWL REBUILD
 REPLACE 4-10' COLUMN, 1-5' COLUMN

WELL & PUMP NO. 4
 CHASKA, MINNESOTA
 RECORD PLAN

JANUARY 2014

FILE NO. 193802345

WELL DATA:

DRILLER: LAYNE MINNESOTA CO.
 DRILLING DATE: AUG. 25, 1975
 STATIC WATER LEVEL: 148 FT.
 PUMPING LEVEL: 323 FT. AT 1800 GPM
 ORIGINAL CASING EL.: 895 ASSUMED

PUMP DATA

INSTALLER: KEYS WELL DRILLING
 INSTALLATION DATE: APRIL 2005
 CAPACITY: 1800 GPM, 427 FT, 1760 RPM
 DESIGN PUMPING LEVEL: 362 FT
 POWER: 460 VOLTS 3 PHASE
 4/19/05 STATIC W.L. 161 FT

WELL LOG:

DEPTH IN FEET	DESCRIPTION
0	CASING EL. 895.2
56	CLAY
105	BLUE SHALE, SAND
180	SHALE, ROCKS, GRAVEL
190	SHALE, SAND
217	LIMESTONE, GRAVEL
225	BLUE SHALE, SAND
287	REDDISH SANDSTONE
390	ST. LAWRENCE
487	GREEN SHALE
588	SANDSTONE
614	GREEN SHALE
655	RED SHALE
773	REDDISH SANDSTONE

MGS

0-190	DRIFT
190-210	PDC
210-300	JOR
300-340	STL
340-487	FRN
487-545	IGL
545-614	ECR
614-773	MTS

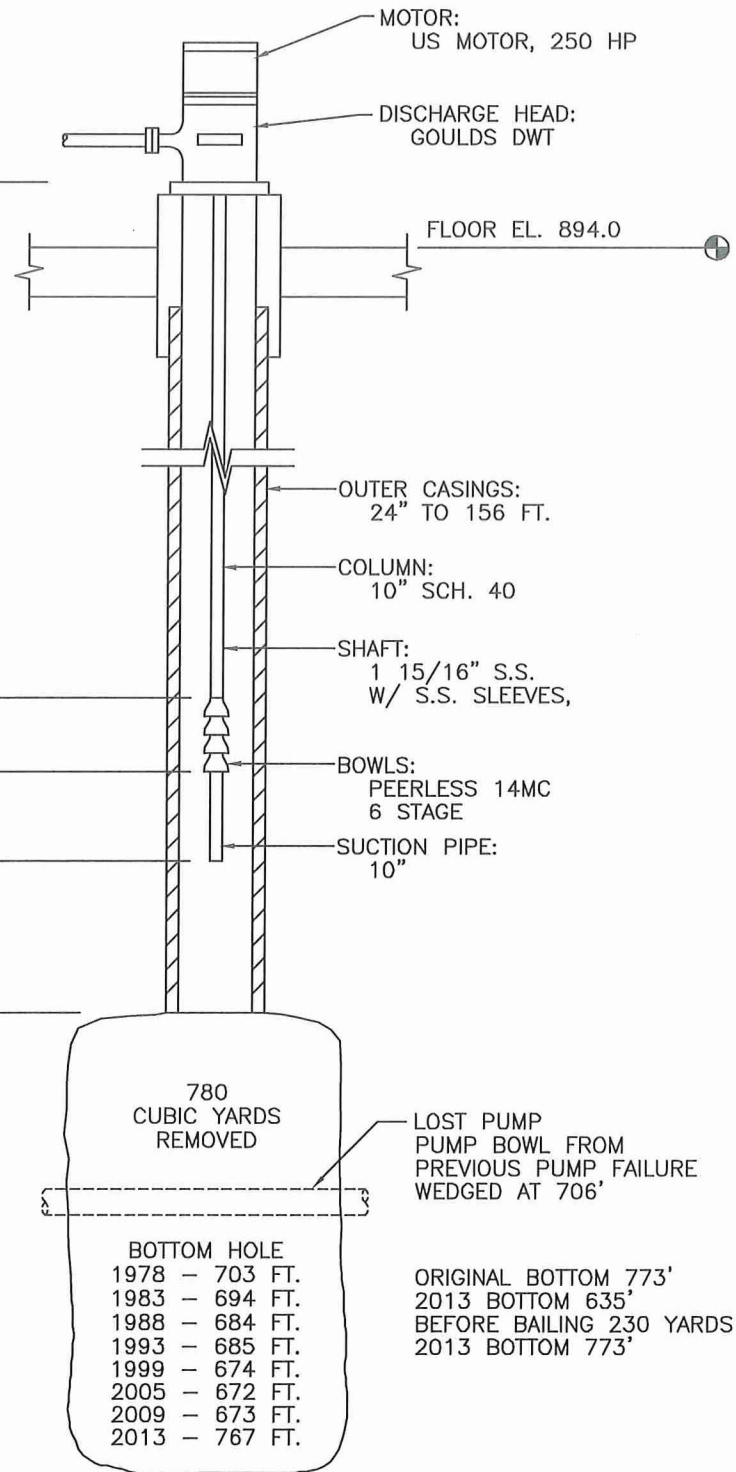

780 CUBIC YARDS REMOVED

BOTTOM HOLE

1978	- 703 FT.
1983	- 694 FT.
1988	- 684 FT.
1993	- 685 FT.
1999	- 674 FT.
2005	- 672 FT.
2009	- 673 FT.
2013	- 767 FT.

LOST PUMP PUMP BOWL FROM PREVIOUS PUMP FAILURE WEDGED AT 706'

ORIGINAL BOTTOM 773'
 2013 BOTTOM 635'
 BEFORE BAILING 230 YARDS
 2013 BOTTOM 773'

193802460W5.dwg



UNIQUE WELL No.: 110453 INSTALLED: 1976
 REPAIRED: 1978 - NEW BOWL
 1983 - ALL COLUMN, MOST SHAFT
 1988 - NEW BOWL, MOST COL., SOME SHAFT
 1993 - MOST COL., SS SHAFT
 1999 - MOST COL., MOTOR REPAIR, LEVEL MONITOR, TELEWISE
 2005 - NEW MOTOR, 295' COL., REPAIR BOWL
 2009 - REPLACED 400' COL. PIPE
 REPLACED BOWL ASSEMBLY
 2013 - REPAIRED MOTOR AND BOWL
 AIRLIFTED 230 CUBIC YARDS

WELL & PUMP NO. 5
 CHASKA, MINNESOTA
 RECORD PLAN

JANUARY, 2014
 FILE NO. 193802460

WELL DATA:

DRILLER: BERGERSON-CASWELL, INC.
 DRILLING DATE: JUNE 29, 1984
 STATIC WATER LEVEL: 190'
 PUMPING LEVEL: 268 FT. AT 1800 GPM
 ORIGINAL CASING EL.: 900.69

PUMP DATA

INSTALLER: KEYS WELL DRILLING
 INSTALLATION DATE: JANUARY 2005
 CAPACITY: 1800 GPM, 412', 1770 RPM
 DESIGN PUMPING LEVEL: 321 FT.
 POWER: 460 VOLTS, 3 PHASE
 4/27/99 STATIC W.L. 229 FT.

WELL LOG:

DEPTH IN FEET

0 CASING EL 900.69

CLAY
 180
 LIMESTONE
 230
 JORDAN SANDSTONE
 300
 ST. LAWRENCE
 335
 FRANCONIA
 508
 IRONTON - GALESVILLE
 569
 EAU CLAIRE
 672
 MT. SIMON - HINCKLEY
 817

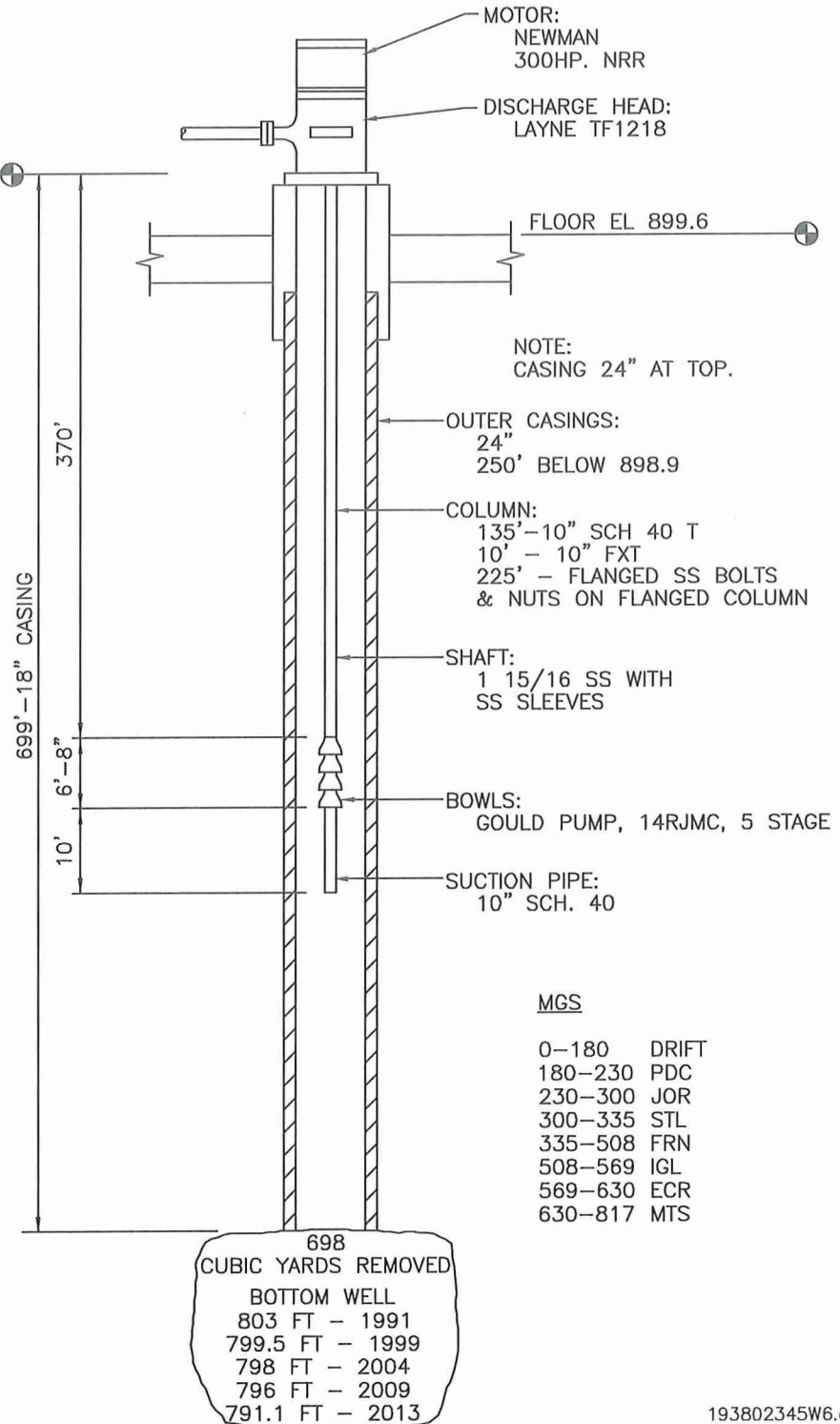

NOTE:
CASING 24" AT TOP.

OUTER CASINGS:
24"
250' BELOW 898.9

COLUMN:
135' - 10" SCH 40 T
10' - 10" FXT
225' - FLANGED SS BOLTS
& NUTS ON FLANGED COLUMN

SHAFT:
1 15/16 SS WITH
SS SLEEVES

BOWLS:
GOULD PUMP, 14RJMC, 5 STAGE

SUCTION PIPE:
10" SCH. 40

MGS

0-180 DRIFT
 180-230 PDC
 230-300 JOR
 300-335 STL
 335-508 FRN
 508-569 IGL
 569-630 ECR
 630-817 MTS

698
 CUBIC YARDS REMOVED
 BOTTOM WELL
 803 FT - 1991
 799.5 FT - 1999
 798 FT - 2004
 796 FT - 2009
 791.1 FT - 2013

193802345W6.dwg



UNIQUE WELL No.: 161435 INSTALLED: 1985
 REPAIRED:
 1999 - REPLACE 60% COLUMN
 REPLACE STEEL SHAFT
 REPLACE DI RETAINER
 BOWL & MOTOR REPAIR
 2005 - REPAIR BOWL & MOTOR
 MINOR COLUMN, NO SHAFT
 2009 - REPLACE 120' COL. PIPE
 REPLACE 37 RUBBER BEARING
 2013 - REPAIR MOTOR, REPLACE PUMP

WELL & PUMP NO. 6
 CHASKA, MINNESOTA
 RECORD PLAN

JANUARY, 2014
 FILE NO. 193802345

WELL DATA:

DRILLER: LTP ENTERPRISES
 DRILLING DATE: SEPTEMBER 1995
 STATIC WATER LEVEL: 170 FT
 PUMPING LEVEL: 195 FT. @ 1700 GPM
 ORIGINAL CASING ELEV.: X

PUMP DATA

INSTALLER: KEYS WELL DRILLING
 INSTALLATION DATE: MAY 2010
 CAPACITY: 1700 GPM, 360 FT, 1800 RPM
 DESIGN PUMPING LEVEL: 195 FT
 POWER: 460 VOLTS 3 PHASE
 2010 STATIC W.L.: 178 FT

WELL LOG:

DEPTH IN FEET

0 CASING EL 965.38

0

CASING EL 965.38

MOTOR:
 U.S. MOTORS
 200 HP

DISCHARGE HEAD:
 AMERICAN TURBINE, HH40
 10"x8"x16 1/2"

FLOOR EL 964.00

OUTER CASINGS:
 295'-14"

COLUMN:
 8", SCH. 40

SHAFT:
 1 11/16"
 230'-STN. STL. SHAFT
 w/ SS SLEEVE

BOWLS:
 AMERICAN TURBINE
 12-X-180, 6 STAGE,
 BRONZE WEAR RING

SUCTION PIPE:
 10' - 8"

JOHNSON "K" PACKER

JOHNSON 12" PS, STN. STL. SCREEN
 3'-TIGHT WIND
 4'-18 SLOT
 35'-20 SLOT
 10'-26 SLOT
 9'-44 SLOT
 4'-49 SLOT
 12'-35 SLOT

SEE WELL LOG
 FOR FORMATIONS

REPAIRED:
 2002 - SOME COL. &
 SHAFT, BOWL REPAIR

2010 - HALF COL. BOWL
 & MOTOR REPAIR, BRUSH
 & TV LEVEL MONITOR

2015 - REPLACE STEEL SHAFT
 WITH STAINLESS STEEL SHAFT,
 REPLACE RUBBER BEARINGS
 BRUSH AND TV WELL
 REPLACE DISCHARGE HEAD
 BOWL AND MOTOR REPAIRS

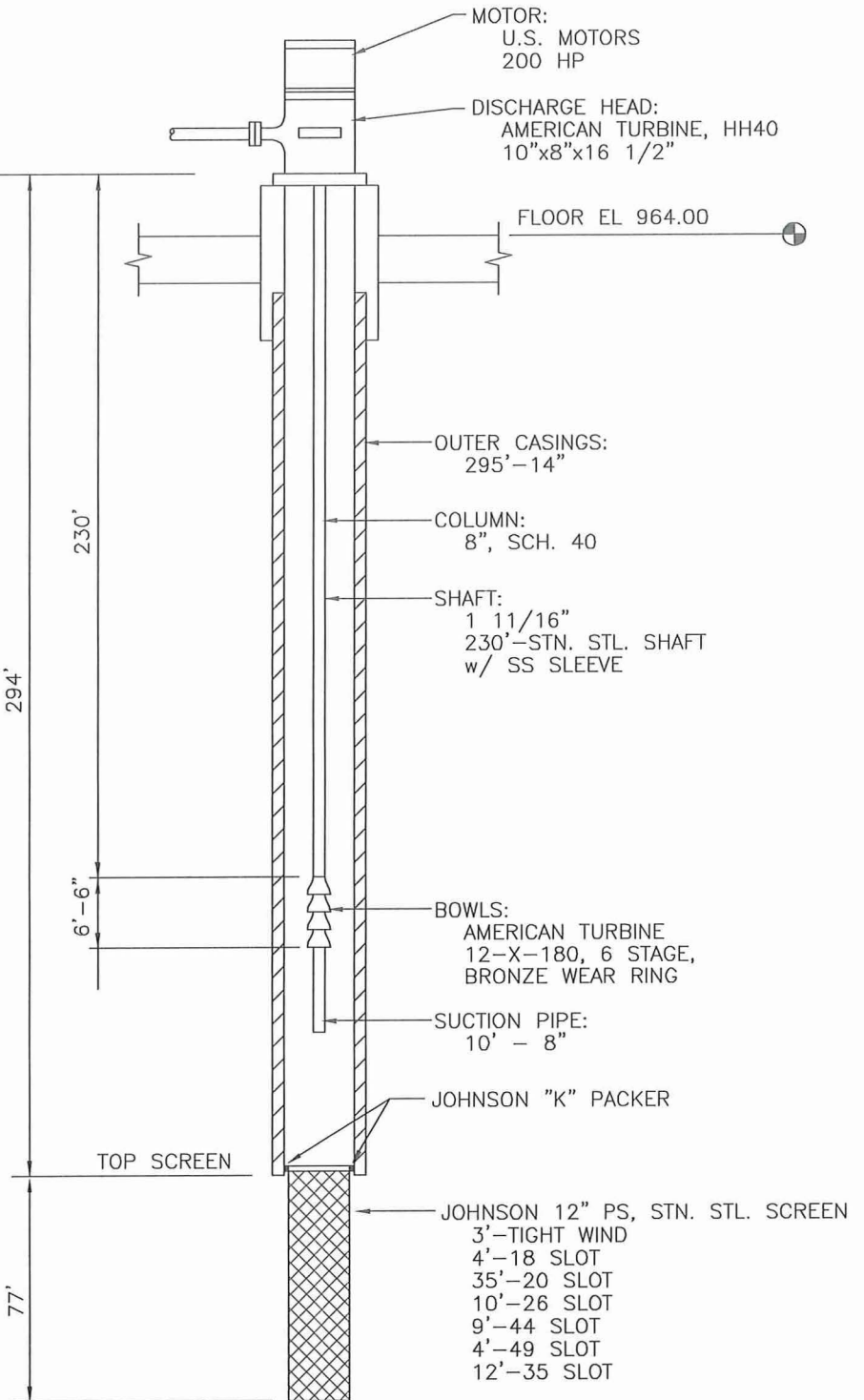

400

193803092F04.DWG



2335 Highway 36 W
 St. Paul, MN 55113
 www.stantec.com

UNIQUE WELL No.: 557822
 INSTALLED: 1996

WELL & PUMP NO. 7
 CHASKA, MINNESOTA
 RECORD PLAN

MAY, 2015

FILE NO. 193803092

WELL DATA:

DRILLER: TRAUT WELLS INC.
DRILLING DATE: APRIL 2002
STATIC WATER LEVEL: 126 FT 198 FT
PUMPING LEVEL: 211 FT @ 723 GPM
ORIGINAL CASING EL.: 903.74

5-1-14

PUMP DATA

INSTALLER: TRAUT WELLS INC.
INSTALLATION DATE: APRIL 3, 2003
CAPACITY: 1200 GPM, 300 FT, 1570 RPM
CAPACITY: 860 GPM, 472 FT, 1700 RPM
DESIGN PUMPING LEVEL: 295 FT, FUTURE 333 FT
POWER: 460 VOLTS 3 PHASE

WELL LOG:

DEPTH IN FEET

0 PITLESS EL 906.17'

222 — PRAIRIE DU CHIEN
234 —
337 —
378 —
518 —
573 — EAU CLAIRE
580 —

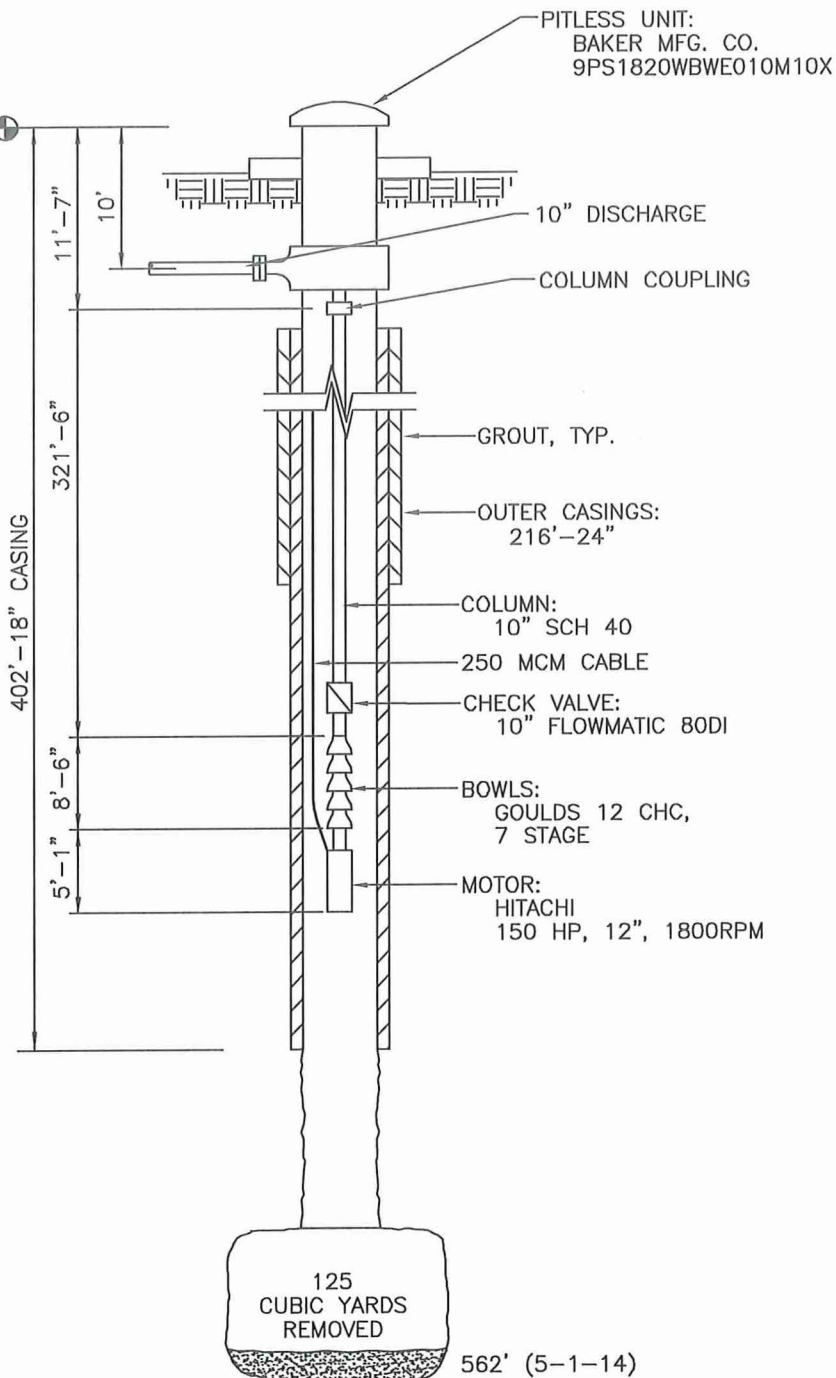

193802683W01.DWG



UNIQUE WELL No.: 674318 INSTALLED:
2003
REPAIRED: 2006 NEW MOTOR
REPAIRED: 2009 NEW COLUMN,
REPAIRED BOWLS & MOTOR
REPAIRED: 2014 NEW COLUMN (EPOXY)
COATED) REPAIRED BOWLS, & ADDED
20' TO PUMP SETTING.

WELL & PUMP NO. 8
CHASKA, MINNESOTA
RECORD PLAN

MAY 2014

FILE NO. 193802683

WELL DATA:

DRILLER: TRAUT WELLS INC.
 DRILLING DATE: JUNE 2002
 STATIC WATER LEVEL: 117'
 PUMPING LEVEL: 181 FT. @ 1000 GPM
 ORIGINAL CASING EL.: 903.01

PUMP DATA

INSTALLER: TRAUT WELLS INC.
 INSTALLATION DATE: APRIL 2, 2003
 CAPACITY: 1000 GPM, 232 FT, 1440 RPM
 CAPACITY: 1000 GPM, 397 FT, 1720 RPM
 DESIGN PUMPING LEVEL: FUTURE 214 FT
 POWER: 460 VOLTS 3 PHASE

WELL LOG:

DEPTH IN FEET

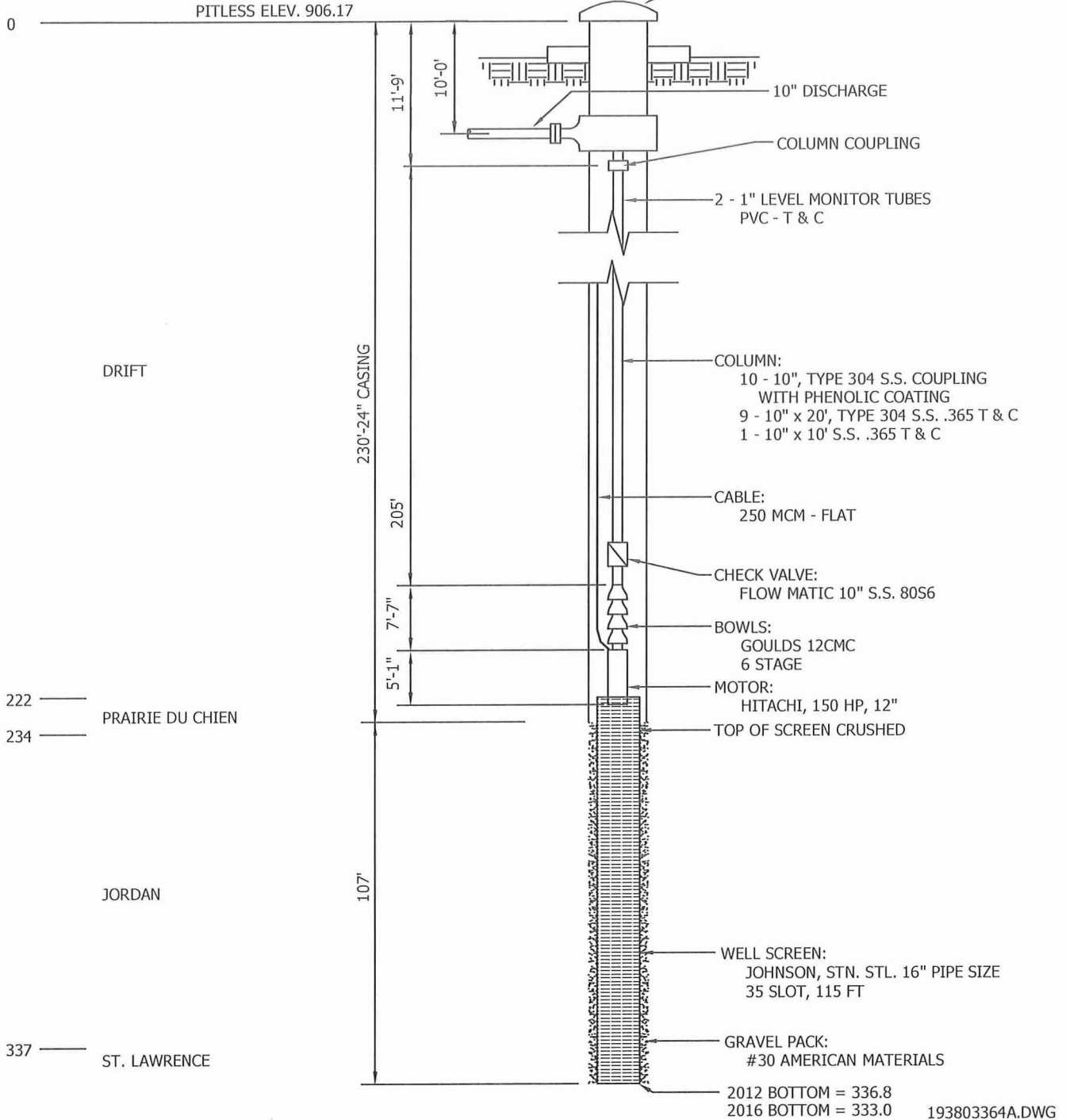

UNIQUE WELL No.: 677176
 INSTALLED: 4/2/2003
 REPAIRED: 2/16/2012
 2012 NEW COLUMN, NEW BOWL

REPAIRED 6/30/2016
 STAINLESS STEEL COLUMN
 STAINLESS STEEL CHECK VALVE

**WELL & PUMP NO. 9
 CHASKA, MINNESOTA
 RECORD PLAN**

JUNE, 2016

FILE NO. 193803364

2006 Water Pumping Report

Month	Well #4	Well #5	Well #6	Well #7	Well #8	Well #9	Total all Wells	Sludge to Sanitary Sewer	Total to System
Jan-06	0	22,615,000	19,626,000	1,031,000	9,945,000	9,107,000	62,324,000	219,200	62,104,800
Feb-06	0	16,847,000	17,071,000	4,097,000	10,683,000	7,984,000	56,682,000	107,400	56,574,600
Mar-06	9,164,000	19,316,000	9,740,000	2,392,000	9,642,000	10,316,000	60,570,000	57,129	60,512,871
Apr-06	14,601,000	12,523,000	16,276,000	3,779,000	15,496,000	8,483,000	71,158,000	505,570	70,652,430
May-06	19,318,000	35,521,000	24,649,000	2,707,000	510,000	27,767,000	110,472,000	86,755	110,385,245
Jun-06	31,358,000	52,109,000	34,066,000	15,625,000	17,056,000	21,467,000	171,681,000	113,441	171,567,559
Jul-06	32,861,000	48,798,000	54,536,000	15,807,000	32,453,000	26,521,000	210,976,000	212,598	210,763,402
Aug-06	25,086,000	40,817,000	31,447,000	2,236,000	24,980,000	21,928,000	146,494,000	184,839	146,309,161
Sep-06	14,936,000	26,520,000	16,511,000	2,686,000	15,558,000	16,028,000	92,239,000	412,999	91,826,001
Oct-06	27,247,000	5,008,000	21,874,000	1,180,000	18,415,000	9,926,000	83,650,000	261,991	83,388,009
Nov-06	16,983,000	14,563,000	9,600,000	1,166,000	12,722,000	7,919,000	62,953,000	66,369	62,886,631
Dec-06	10,433,000	13,726,000	15,500,000	1,666,000	12,672,000	6,568,000	60,565,000	56,612	60,508,388
Total	201,987,000	308,363,000	270,896,000	54,372,000	180,132,000	174,014,000	1,189,764,000	2,284,903	
							1,187,479,097		
							Total to System		

2007 Water Pumping Report

Month	Well #4	Well #5	Well #6	Well #7	Well #8	Well #9	Total all Wells	Sludge to Sanitary Sewer	Total to System
Jan-07	10,861,000	15,252,000	17,747,000	1,498,000	2,735,000	13,770,000	61,863,000	37,547	61,825,453
Feb-07	20,942,000	10,355,000	10,894,000	1,330,000	0	14,740,000	58,261,000	31,258	58,229,742
Mar-07	9,656,000	20,264,000	14,476,000	778,000	3,128,000	14,056,000	62,358,000	29,564	62,328,436
Apr-07	18,170,000	12,698,000	18,551,000	0	14,577,000	8,967,000	72,963,000	77,150	72,885,850
May-07	29,570,000	34,692,000	12,330,000	1,178,000	21,429,000	17,535,000	116,734,000	72,512	116,661,488
Jun-07	35,500,000	28,903,000	48,353,000	9,287,000	28,935,000	25,448,000	176,426,000	161,294	176,264,706
Jul-07	33,748,000	41,461,000	59,316,000	27,451,000	30,656,000	31,541,000	224,173,000	162,425	224,010,575
Aug-07	26,295,000	28,028,000	35,353,000	11,843,000	21,981,000	24,043,000	147,543,000	120,166	147,422,834
Sep-07	17,499,000	28,768,000	26,804,000	5,174,000	19,194,000	17,322,000	114,761,000	88,435	114,672,565
Oct-07	16,451,000	10,250,000	17,685,000	2,179,000	15,009,000	12,965,000	74,539,000	89,837	74,449,163
Nov-07	13,164,000	18,019,000	10,644,000	923,000	11,881,000	9,729,000	64,360,000	55,880	64,304,120
Dec-07	15,202,000	8,226,000	17,048,000	1,433,000	10,332,000	11,574,000	63,815,000	141,003	63,673,997
Total	247,058,000	256,916,000	289,201,000	63,074,000	179,857,000	201,690,000	1,237,796,000	1,067,071	1,236,728,929
							Total Wells Backwash		

2008 Water Pumping Report

Month	Well #4	Well #5	Well #6	Well #7	Well #8	Well #9	Total all Wells	Sludge to Sanitary Sewer	Total to System
Jan-08	14,955,000	15,086,000	11,798,000	1,306,000	10,619,000	10,910,000	64,674,000	123,149	64,550,851
Feb-08	14,332,000	8,651,000	14,525,000	1,098,000	10,450,000	9,032,000	58,088,000	88,579	57,999,421
Mar-08	7,200,000	17,495,000	13,377,000	416,000	10,813,000	9,807,000	59,108,000	143,871	58,964,129
Apr-08	19,106,000	12,376,000	14,083,000	797,000	19,531,000	2,836,000	68,729,000	196,437	68,532,563
May-08	21,402,000	28,584,000	25,201,000	352,000	27,800,000	0	103,339,000	261,525	103,077,475
Jun-08	28,519,000	28,582,000	31,364,000	1,868,000	26,776,000	14,406,000	131,515,000	201,124	131,313,876
Jul-08	30,214,000	41,164,000	40,877,000	11,217,000	28,925,000	27,144,000	179,541,000	288,289	179,252,711
Aug-08	36,161,000	28,747,000	36,985,000	7,732,000	30,154,000	26,595,000	166,374,000	214,288	166,159,712
Sep-08	23,862,000	17,774,000	27,531,000	878,000	23,205,000	17,684,000	110,934,000	150,760	110,783,240
Oct-08	22,362,000	9,540,000	14,072,000	252,000	13,766,000	16,978,000	76,970,000	170,935	76,799,065
Nov-08	7,545,000	14,818,000	10,517,000	1,807,000	13,022,000	12,706,000	60,415,000	140,528	60,274,472
Dec-08	14,199,000	4,184,000	15,996,000	0	14,105,000	11,825,000	60,309,000	187,931	60,121,069
Total	239,857,000	227,001,000	256,326,000	27,723,000	229,166,000	159,923,000	1,139,996,000	2,167,416	
							1,137,828,584		
							Total Wells Backwash		

Working on Well #9 in May
Well #5 went down in December

2009 Water Pumping Report

Month	Well #4	Well #5	Well #6	Well #7	Well #8	Well #9	Total all Wells	Sludge to Sanitary Sewer	Total to System
Jan-09	22,551,000	0	14,752,000	607,000	12,761,000	13,360,000	64,031,000	70,729	63,960,271
Feb-09	16,269,000	1,000	15,130,000	297,000	13,442,000	11,180,000	56,319,000	40,078	56,278,922
Mar-09	17,549,000	12,509,000	6,328,000	902,000	13,748,000	10,561,000	61,597,000	210,955	61,386,045
Apr-09	3,674,000	46,949,000	0	2,105,000	17,645,000	11,897,000	82,270,000	329,723	81,940,277
May-09	18,318,000	50,069,000	33,037,000	3,191,000	733,000	26,966,000	132,314,000	57,834	132,256,166
Jun-09	38,900,000	41,096,000	36,350,000	5,868,000	0	28,407,000	150,621,000	102,320	150,518,680
Jul-09	19,543,000	40,262,000	53,089,000	19,102,000	8,817,000	31,717,000	172,530,000	47,889	172,482,111
Aug-09	1,082,000	10,259,000	56,326,000	7,304,000	15,220,000	27,821,000	118,012,000	106,033	117,905,967
Sep-09	27,466,000	27,802,000	18,412,000	4,872,000	28,068,000	21,729,000	128,349,000	47,563	128,301,437
Oct-09	22,784,000	17,697,000	4,361,000	0	10,894,000	13,115,000	68,851,000	12,894,000	55,957,000
Nov-09	23,688,000	9,316,000	6,772,000	436,000	10,676,000	9,134,000	60,022,000	34,465	59,987,535
Dec-09	11,645,000	13,405,000	15,006,000	268,000	9,301,000	11,464,000	61,089,000	35,900	61,053,100
Total	223,469,000	269,365,000	259,563,000	44,952,000	141,305,000	217,351,000	1,156,005,000	13,977,489	

Well # 5 went down in December 2008

Well # 6 Maintenance work March, April 2009

Well # 8 Maintenance work May 2009

1,142,027,511
Total Wells Backwash

2010 Water Pumping Report

Month	Well #4	Well #5	Well #6	Well #7	Well #8	Well #9	Total all Wells	Sludge to Sanitary Sewer	Total to System
Jan-10	15,726,000	9,611,000	13,409,000	469,000	9,817,000	12,884,000	61,916,000	17,766	61,898,234
Feb-10	6,898,000	17,511,000	13,720,000	493,000	10,393,000	9,840,000	58,855,000	53,959	58,801,041
Mar-10	0	14,869,000	30,357,000	0	7,217,000	14,546,000	66,989,000	13,383	66,975,617
Apr-10	1,717,000	35,406,000	22,356,000	498,000	18,751,000	12,371,000	91,099,000	38,465	91,060,535
May-10	27,236,000	27,281,000	16,782,000	1,291,000	21,608,000	15,692,000	109,890,000	123,315	109,766,685
Jun-10	16,247,000	28,675,000	20,000,000	217,000	24,992,000	13,076,000	103,207,000	53,051	103,153,949
Jul-10	34,012,000	32,414,000	18,324,000	462,000	28,448,000	21,065,000	134,725,000	96,146	134,628,854
Aug-10	21,385,000	30,847,000	31,872,000	576,000	28,660,000	21,212,000	134,552,000	65,273	134,486,727
Sep-10	27,905,000	17,402,000	16,006,000	142,000	20,683,000	12,797,000	94,935,000	56,685	94,878,315
Oct-10	15,962,000	16,354,000	20,318,000	189,000	14,290,000	13,347,000	80,460,000	37,322	80,422,678
Nov-10	13,140,000	8,868,000	16,614,000	198,000	14,886,000	7,092,000	60,798,000	21,962	60,776,038
Dec-10	12,865,000	14,344,000	14,268,000	0	12,588,000	9,009,000	63,074,000	112,031	62,961,969
Total	193,093,000	253,582,000	234,026,000	4,535,000	212,333,000	162,931,000	1,060,500,000	689,358	
							1,059,810,642		
							Total Wells Backwash		

Well #4 Maintenance work done in March by Keys Well Drilling

2011 Water Pumping Report

Month	Well #4	Well #5	Well #6	Well #7	Well #8	Well #9	Total all Wells	Sludge to Sanitary Sewer	Total to System
Jan-11	10,935,000	16,698,000	15,594,000	177,000	14,591,000	8,824,000	66,819,000	141,283	66,677,717
Feb-11	14,282,000	9,540,000	16,529,000	292,000	9,522,000	9,950,000	60,115,000	27,742	60,087,258
Mar-11	15,201,000	18,624,000	8,636,000	129,000	12,997,000	8,430,000	64,017,000	73,366	63,943,634
Apr-11	15,881,000	14,422,000	14,983,000	129,000	14,190,000	11,393,000	70,998,000	682,612	70,315,388
May-11	12,413,000	22,422,000	17,337,000	166,000	13,086,000	12,451,000	77,875,000	336	77,874,664
Jun-11	24,054,000	22,599,000	21,075,000	2,394,000	22,630,000	19,713,000	112,465,000	89,085	112,375,915
Jul-11	21,514,000	32,165,000	28,440,000	296,000	30,949,000	26,570,000	139,934,000	62,470	139,871,530
Aug-11	30,396,000	23,260,000	24,490,000	61,000	33,648,000	27,061,000	138,916,000	53,205	138,862,795
Sep-11	27,203,000	31,048,000	30,275,000	5,515,000	25,911,000	23,298,000	143,250,000	109,416	143,140,584
Oct-11	22,731,000	30,156,000	13,794,000	1,752,000	19,289,000	16,106,000	103,828,000	37,796	103,790,204
Nov-11	7,364,000	15,407,000	19,608,000	0	10,342,000	9,983,000	62,704,000	15,485	62,688,515
Dec-11	12,727,000	19,532,000	11,543,000	0	12,063,000	9,719,000	65,584,000	49,827	65,534,173
Total	214,701,000	255,873,000	222,304,000	10,911,000	219,218,000	183,498,000	1,106,505,000	1,342,623	
							1,105,162,377		
							Total Wells Backwash		

April - sludge was high due to filter media added

2012 Water Pumping Report

Month	Well #4	Well #5	Well #6	Well #7	Well #8	Well #9	Total all Wells	Sludge to Sanitary Sewer	Total to System
Jan-12	14,343,000	10,732,000	16,429,000	117,000	8,594,000	11,914,000	62,129,000	51,294	62,077,706
Feb-12	10,815,000	21,411,000	6,848,000	187,000	14,908,000	4,578,000	58,747,000	327	58,746,673
Mar-12	11,715,000	10,477,000	19,082,000	745,000	22,147,000	0	64,166,000	466,790	63,699,210
Apr-12	19,091,000	15,182,000	11,595,000	449,000	16,726,000	9,137,000	72,180,000	185,847	71,994,153
May-12	14,100,000	23,225,000	25,241,000	639,000	22,583,000	15,202,000	100,990,000	62,565	100,927,435
Jun-12	33,151,000	28,834,000	21,071,000	2,650,000	24,008,000	22,467,000	132,181,000	51,912	132,129,088
Jul-12	46,709,000	19,703,000	53,269,000	16,368,000	22,286,000	28,936,000	187,271,000	150,797	187,120,203
Aug-12	50,327,000	27,401,000	19,881,000	2,144,000	24,608,000	29,098,000	153,459,000	82,575	153,376,425
Sep-12	51,916,000	35,592,000	12,764,000	394,000	30,101,000	23,988,000	154,755,000	100,093	154,654,907
Oct-12	14,914,000	21,662,000	18,642,000	483,000	25,477,000	18,092,000	99,270,000	68,557	99,201,443
Nov-12	16,522,000	10,410,000	9,319,000	109,000	17,355,000	10,108,000	63,823,000	42,009	63,780,991
Dec-12	16,319,000	16,023,000	8,394,000	262,000	19,129,000	3,275,000	63,402,000	40,326	63,361,674
Total	299,922,000	240,652,000	222,535,000	24,547,000	247,922,000	176,795,000	1,212,373,000	1,303,092	
							1,211,069,908		
							Total Wells Backwash		

Well #9 went down for 5yr maintenance on 02/13/12

2013 Water Pumping Report

Month	Well #4	Well #5	Well #6	Well #7	Well #8	Well #9	Total all Wells	Sludge to Sanitary Sewer	Total to System
Jan-13	11,321,000	12,894,000	18,896,000	403,000	19,866,000	0	63,380,000	42386	63,337,614
Feb-13	2,132,000	14,888,000	16,002,000	441,000	13,171,000	10,010,000	56,644,000	10222	56,633,778
Mar-13	17,573,000	9,396,000	6,986,000	0	18,286,000	11,114,000	63,355,000	92559	63,262,441
Apr-13	7,064,000	34,020,000	0	328,000	14,519,000	15,195,000	71,126,000	62437	71,063,563
May-13	0	23,505,000	20,995,000	285,000	20,487,000	14,579,000	79,851,000	42962	79,808,038
Jun-13	0	22,733,000	24,289,000	295,000	19,660,000	17,200,000	84,177,000	84081	84,092,919
Jul-13	0	48,338,000	41,678,000	6,446,000	30,147,000	27,013,000	153,622,000	47621	153,574,379
Aug-13	44,025,000	31,304,000	26,014,000	6,834,000	28,383,000	25,420,000	161,980,000	66699	161,913,301
Sep-13	50,844,000	22,812,000	16,690,000	3,977,000	24,937,000	24,646,000	143,906,000	55297	143,850,703
Oct-13	23,220,000	1,806,000	18,687,000	125,000	20,545,000	16,140,000	80,523,000	62406	80,460,594
Nov-13	16,695,000	0	19,226,000	177,000	17,448,000	9,215,000	62,761,000	1963	62,759,037
Dec-13	17,874,000	0	21,143,000	390,000	16,480,000	11,922,000	67,809,000	81784.00	67,727,216
Total	190,748,000	221,696,000	230,606,000	19,701,000	243,929,000	182,454,000	1,089,134,000	650,417	
							1,088,483,583		
							Total Wells Backwash		

Well 9 transducer replaced Jan 2013

Well 4 draw down concerns impacting useage ~ started Apr 25, 2013 ~Completed Aug. 7th 2013

Well 6 down for 4 year Maintenance starts March 2013~ Started back up in May 2013

Well 5 down for 4 year Maintenance starts October 2013

2014 Water Pumping Report

Month	Well #4	Well #5	Well #6	Well #7	Well #8	Well #9	Total all Wells	Sludge to Sanitary Sewer	Total to System
Jan-14	14,917,000	20,739,000	6,052,000	315,000	20,638,000	8,411,000	71,072,000	205000	70,867,000
Feb-14	22,268,000	4,446,000	12,187,000	138,000	16,096,000	11,291,000	66,426,000	246384	66,179,616
Mar-14	16,511,000	21,838,000	11,081,000	0	6,922,000	9,644,000	65,996,000	73151	65,922,849
Apr-14	20,671,000	20,964,000	23,400,000	101,000	0	5,427,000	70,563,000	157182	70,405,818
May-14	21,760,000	17,468,000	15,156,000	21,000	16,316,000	15,140,000	85,861,000	103156	85,757,844
Jun-14	16,444,000	13,910,000	20,754,000	0	23,023,000	15,273,000	89,404,000	74694	89,329,306
Jul-14	25,209,000	22,011,000	30,810,000	6,470,000	25,680,000	21,535,000	131,715,000	150029	131,564,971
Aug-14	36,471,000	30,235,000	23,092,000	5,653,000	29,707,000	24,211,000	149,369,000	166872	149,202,128
Sep-14	22,239,000	21,508,000	13,666,000	39,000	25,223,000	20,538,000	103,213,000	130863	103,082,137
Oct-14	11,926,000	12,211,000	19,449,000	0	18,789,000	16,660,000	79,035,000	128597	78,906,403
Nov-14	0	19,033,000	15,855,000	0	16,150,000	9,976,000	61,014,000	78590	60,935,410
Dec-14	0	22,031,000	13,052,000	131,000	15,833,000	11,609,000	62,656,000	81146.00	62,574,854
Total	208,416,000	226,394,000	204,554,000	12,868,000	214,377,000	169,715,000	1,036,324,000	1,595,664	
							1,034,728,336		
							Total Wells Backwash		

** Well #8 Rehab 4/1/14 **

**Well #4 out of service 10/22/14

2015 Water Pumping Report

Month	Well #4	Well #5	Well #6	Well #7	Well #8	Well #9	Total all Wells	Sludge to Sanitary Sewer	Total to System
Jan-15	0	15,910,000	21,877,000	0	15,346,000	11,389,000	64,522,000	138530	64,383,470
Feb-15	71,000	18,215,000	18,799,000	0	14,177,000	9,079,000	60,341,000	112330	60,228,670
Mar-15	12,584,000	20,989,000	11,172,000	51,000	11,240,000	12,966,000	69,002,000	96699	68,905,301
Apr-15	9,613,000	21,884,000	15,636,000	0	16,926,000	14,353,000	78,412,000	145867	78,266,133
May-15	21,926,000	18,240,000	11,703,000	72,000	22,778,000	16,264,000	90,983,000	72104	90,910,896
Jun-15	21,181,000	23,261,000	23,599,000	313,000	25,229,000	15,410,000	108,993,000	141551	108,851,449
Jul-15	18,076,000	28,082,000	31,982,000	2,920,000	23,331,000	15,117,000	119,508,000	143,592	119,364,408
Aug-15	29,983,000	28,351,000	27,873,000	62,000	21,582,000	19,307,000	127,158,000	146227	127,011,773
Sep-15	22,236,000	28,335,000	17,613,000	0	18,173,000	15,786,000	102,143,000	129154	102,013,846
Oct-15	14,369,000	21,331,000	19,340,000	0	14,790,000	13,194,000	83,024,000	92299	82,931,701
Nov-15	11,158,000	13,108,000	17,191,000	0	10,821,000	10,191,000	62,469,000	74959	62,394,041
Dec-15	10,806,000	19,039,000	9,422,000	18,000	13,176,000	11,502,000	63,963,000	128000.00	63,835,000
Total	172,003,000	256,745,000	226,207,000	3,436,000	207,569,000	164,558,000	1,030,518,000	1,421,312	
							1,029,096,688		
							Total Wells Backwash		

**Well #4 out of service 10/22/14

**Well #7, out of service for rehab March 2015

2016 Water Pumping Report

Month	Well #4	Well #5	Well #6	Well #7	Well #8	Well #9	Total all Wells	Sludge to Sanitary Sewer	Total to System
Jan-15	12,545,000	17,123,000	8,836,000	0	14,422,000	12,244,000	65,170,000	104336	65,065,664
Feb-15	14,461,000	11,364,000	13,907,000	48,000	15,224,000	5,402,000	60,406,000	79303	60,326,697
Mar-15	15,552,000	18,280,000	11,193,000	0	17,332,000	0	62,357,000	115515	62,241,485
Apr-15	21,936,000	17,312,000	15,177,000	0	18,503,000	0	72,928,000	144472	72,783,528
May-15	23,067,000	28,410,000	25,795,000	0	23,515,000	0	100,787,000	75859	100,711,141
Jun-15	34,121,000	28,163,000	38,529,000	698,000	26,766,000	1,468,000	129,745,000	179569	129,565,431
Jul-15	28,786,000	39,190,000	32,489,000	4,723,000	26,869,000	23,400,000	155,457,000	206,353	155,250,647
Aug-15	25,373,000	18,740,000	29,700,000	564,000	22,145,000	18,828,000	115,350,000	152759	115,197,241
Sep-15									
Oct-15									
Nov-15									
Dec-15									
Total	175,841,000	178,582,000	175,626,000	6,033,000	164,776,000	61,342,000	762,200,000	1,058,166	
							761,141,834		
							Total Wells Backwash		

Well 9 down for rehab 02/24/16 2016 - 06/29/16

APPENDIX 2: WATER LEVEL MONITORING PLAN

CITY OF CHASKA – WATER LEVEL MONITORING PLAN

This plan summarizes the existing groundwater level monitoring efforts that the City undertakes and outlines an expansion of the data collection effort to cover the lifetime of the current amended Water Supply Plan.

Existing Monitoring Program

The City of Chaska currently collects continuous water level monitoring data from all of the active municipal water supply wells. The table below provides information for each well being monitored.

Well Name	Unique Number	Aquifer	Well Depth (feet)	Monitoring Equipment	Monitoring Frequency
Well 4	200809	Tunnel City-Mt. Simon	813	Pressure transducer and SCADA	Hourly
Well 5	110453	Wonewoc-Mt. Simon	773	Pressure transducer and SCADA	Hourly
Well 6	161435	Mt. Simon	817	Pressure transducer and SCADA	Hourly
Well 7	557822	Drift	368	Pressure transducer and SCADA	Hourly
Well 8	674319	Tunnel City-Wonewoc	576	Pressure transducer and SCADA	Hourly
Well 9	677176	Jordan	333	Pressure transducer and SCADA	Hourly

Water level measurements are collected hourly from each well, using the City's SCADA system to record the measurements. At the end of each month, measurements are compiled into a CSV-formatted spreadsheet and submitted to the Minnesota Department of Natural Resources (DNR). A sample of a small portion of one monthly submitted is attached for reference, showing the reporting format utilized for submittal.

Proposed Monitoring Program Additions

The City of Chaska has been working with the DNR to expand the monitoring network to construct dedicated monitoring wells which will supplement the data already being collected in the municipal water supply wells. This is being done as a condition for expansion of the City's well field to add Well 10 to the Tunnel City-Wonewoc aquifer. Chaska staff met with the DNR on September 8, 2016 to identify the locations for future monitoring points. The results of the meeting are outlined in the attached letter, submitted by Chaska to DNR staff on October 3, 2016.

The current plan is to drill three new dedicated monitoring wells, one each in the Drift, Jordan, and Tunnel City aquifers. An existing test well (unique number 674317) completed in the Tunnel City

formation will also be converted as a dedicated monitoring well. Construction of these wells is planned to be completed in 2017, with monitoring set to begin on or before January 2018. A map showing the proposed well locations is included in the October 3, 2016 letter.

These proposed monitoring wells will all be outfitted with similar water level measuring probes that the municipal wells utilize and the wells will use telemetry to relay water level readings, on an hourly basis, to the City's SCADA system. Formatting and reporting of water level data will take place on the same schedule as the municipal water supply wells, with data bundled together as one overall monthly submittal.

The water level monitoring efforts from the municipal water supply wells and dedicated monitoring wells is proposed to occur throughout the 10-year lifetime of the City's amended Water Supply Plan. When the plan is next updated in 2026, monitoring requirements will be reviewed and it will be determined if modifications to the monitoring program are necessary.

date_time	MDH_Well_ID	Volume_HR_MGH	Runtime_HR	Est_Pump_Rate_GPM	Depth_to_Water_FT
10/1/2016 0:04	200809	0.000	0.00	0	217.40
10/1/2016 1:04	200809	0.000	0.00	0	214.10
10/1/2016 2:04	200809	0.000	0.00	0	212.00
10/1/2016 3:04	200809	0.000	0.00	0	210.50
10/1/2016 4:04	200809	0.000	0.00	0	209.20
10/1/2016 5:04	200809	0.000	0.00	0	238.70
10/1/2016 6:04	200809	0.107	0.90	1981	257.30
10/1/2016 7:04	200809	0.107	1.00	1783	271.40
10/1/2016 8:04	200809	0.105	1.00	1750	276.80
10/1/2016 9:04	200809	0.104	1.00	1733	278.10
10/1/2016 10:04	200809	0.041	0.40	1707	227.80
10/1/2016 11:04	200809	0.000	0.00	0	220.10
10/1/2016 12:04	200809	0.000	0.00	0	216.10
10/1/2016 13:04	200809	0.000	0.00	0	213.50
10/1/2016 14:04	200809	0.000	0.00	0	211.60
10/1/2016 15:04	200809	0.051	0.50	1700	252.10
10/1/2016 16:04	200809	0.110	1.00	1833	257.40
10/1/2016 17:04	200809	0.110	1.00	1833	260.00
10/1/2016 18:04	200809	0.108	1.00	1800	261.50
10/1/2016 19:04	200809	0.109	1.00	1817	262.50
10/1/2016 20:04	200809	0.108	1.00	1800	263.30
10/1/2016 21:04	200809	0.108	1.00	1800	264.00
10/1/2016 22:04	200809	0.047	0.50	1567	222.70
10/1/2016 23:04	200809	0.000	0.00	0	216.90
10/2/2016 0:04	200809	0.000	0.00	0	213.90
10/2/2016 1:04	200809	0.000	0.00	0	211.80
10/2/2016 2:04	200809	0.000	0.00	0	210.20
10/2/2016 3:04	200809	0.000	0.00	0	229.30
10/2/2016 4:04	200809	0.097	0.80	2019	253.70
10/2/2016 5:04	200809	0.110	1.00	1833	257.50
10/2/2016 6:04	200809	0.109	1.00	1817	259.50
10/2/2016 7:04	200809	0.109	1.00	1817	261.20
10/2/2016 8:04	200809	0.109	1.00	1817	262.30
10/2/2016 9:04	200809	0.108	1.00	1800	262.60
10/2/2016 10:04	200809	0.108	1.00	1800	263.30
10/2/2016 11:04	200809	0.107	1.00	1783	263.90
10/2/2016 12:04	200809	0.108	1.00	1800	264.60
10/2/2016 13:04	200809	0.107	1.00	1783	242.40
10/2/2016 14:04	200809	0.014	0.20	1171	221.10
10/2/2016 15:04	200809	0.000	0.00	0	216.50
10/2/2016 16:04	200809	0.000	0.00	0	213.70
10/2/2016 17:04	200809	0.000	0.00	0	211.70
10/2/2016 18:04	200809	0.000	0.00	0	223.50
10/2/2016 19:04	200809	0.094	0.80	1956	254.50
10/2/2016 20:04	200809	0.110	1.00	1833	258.20
10/2/2016 21:04	200809	0.109	1.00	1817	260.20
10/2/2016 22:04	200809	0.109	1.00	1817	261.70
10/2/2016 23:04	200809	0.108	1.00	1800	262.70
10/3/2016 0:04	200809	0.108	1.00	1800	263.50
10/3/2016 1:04	200809	0.108	1.00	1800	263.90



Municipal Services Building

City of Chaska, Water & Sewer Department
660 Victoria Drive
Chaska, MN 55318
Ph: 952-448-4335 Fax: 952-448-7356

October 3, 2016

Mr. Joe Richter
District Appropriations Hydrologist
Minnesota Department of Natural Resources
1200 Warner Road
Saint Paul, MN 55106

Re: Letter of Understanding following September 8, 2016 meeting

Dear Mr. Richter:

We appreciate you meeting with us on September 8, 2016 to discuss potential changes to Chaska's water supply system and to review proposed monitoring well locations to help support the growth of our well fields. The purpose of this letter is to articulate our understanding of the meeting's outcome and to lay out the proposed scenario for the water system expansion over the next several years.

Future Municipal Wells

At the time that our previous Water Supply Plan was developed, it was anticipated that the municipal wells would be added in the existing Victoria Well Field (which currently contains Wells 4, 5, 6, 8, and 9). We were planning that the next wells would either be completed in the Jordan aquifer or in the Tunnel City-Wonewoc (TCW) aquifer, formerly known as the Franconia-Ironton-Galesville (FIG) aquifer. One advantage of this scenario was to place the wells in close proximity to our water treatment plant, so that we could streamline the number of raw water mains needed to carry well water to the plant.

Recently, however, the City has decided on an alternate approach. The current plan is to utilize Well No. 7 to a greater amount. Well No. 7 is completed in the drift aquifer and is a highly productive well, but the current manganese levels of the raw water produces widespread complaints from businesses and residents. We are in the process of considering adding a second water treatment plant near Well No. 7. In order to make it feasible to construct a new water treatment plant the City needs to construct a backup well in order to maintain a firm capacity at the plant. This backup well would most likely be completed in the TCW aquifer.

At some point in the future, additional growth or expansion will likely take place in the Victoria Well Field, if population trends continue as expected. But for the near future, no additional growth is expected in this well field.

Monitoring Well Requirements

In November 2009, Evan Drivas provided a memo to Jack Gleason outlining his requirements for a monitoring well network to accommodate the expected growth of Chaska's well field. At that time, it was believed that four new municipal wells would be drilled by the year 2015. To date, no additional municipal wells have been drilled since that memo was written, because water demands haven't increased to the extent that were originally predicted.

The purpose of the monitoring wells was to establish whether pumping from the aquifer(s) that serve the Victoria Well Field would have an impact on groundwater-dependent natural resources in the area. In particular, the primary concern dealt with possible impacts to the Seminary Fen, located approximately 2.25 miles east of the Victoria Well Field (as seen in Figure 1). At that time, Mr. Drivas noted a need for three monitoring wells:

1. One Jordan aquifer well near the north end of the Victoria Well Field, where future Jordan aquifer production wells were expected to be drilled.
2. A nest of two monitoring wells roughly halfway between the Victoria Well Field and the Seminary Fen. These wells were to be completed in both the TCW aquifer and the Jordan aquifer. If the Jordan aquifer was absent at the location indicated in the memo, then a drift aquifer well completed at roughly the same elevation as where the Jordan aquifer is present elsewhere in the City.

Proposed New Monitoring Well Locations

The purpose of our September 8, 2016 meeting was to review the 2009 memo and determine what the optimal monitoring well locations currently are, considering the revised plans to expand Chaska's water supply system. Scott Pearson, a professional geologist from the DNR, was also in attendance to provide guidance to determine the optimal location for these monitoring wells.

The original approach of installing monitoring wells between the well fields and the fen was still considered to be essential. Aquifers to be monitored include the TCW aquifer, the Jordan aquifer, and the drift aquifer where the Jordan is expected to be absent. The attached Figure 1 shows the newly proposed locations of the monitoring wells. At completion, the City is expecting to have four dedicated monitoring wells. These wells include:

1. Existing Well 674317, which is a TCW aquifer test well completed on the Fire Station property. This test well is currently not being regularly used for other purposes, so it could easily be converted to serve as a dedicated monitoring well. The intended purpose of this monitoring well will be to observe drawdown interference from the nearby Victoria Well Field.
2. A Jordan aquifer monitoring well is proposed to be installed next to well 674317 described above. Since the drilling log for the existing well showed that the Jordan aquifer is present in this location, this is expected to be a good location to observe drawdown interference in the Jordan aquifer which results from pumping the Victoria Well Field.
3. A nest of two eastern monitoring wells would be drilled between Mabel Court and Audubon Road, as indicated on Figure 1. This nest would consist of a drift aquifer well, completed at roughly the same elevation of the Jordan aquifer (which is absent at this location) and a TCW aquifer well. The purpose of this well nest would be to look for possible impacts from pumping at municipal Well No. 7 and the proposed future Well No. 10, helping to obtain the information necessary to amend the appropriation permit for these wells. Additionally, if any far

reaching impacts from the Victoria Well Field are present at this location, it is expected that these monitoring wells would also help to observe and quantify those impacts.

The potentiometric surface of the drift and TCW aquifers at these proposed monitoring well locations is expected to be above the elevation of 770 feet. This is the elevation at which seeps in the Seminary Fen have been observed, so it is important that the monitoring wells are higher in elevation than the observed seeps.

As part of the monitoring well construction effort, the City of Chaska will install continuous water level measuring devices in these wells that are connected to our SCADA system. Water levels measurements from these wells will be reported to the DNR at the same frequency that water level data from the municipal wells are currently being reported. The same data formatting structure would be used for all water level measurements to ensure consistency.

Proposed Next Steps

Assuming the above proposed sites meet with DNR approval, the City of Chaska is proposing to move forward with monitoring well construction in the year 2017, in advance of drilling future municipal Well No. 10. During the process of drilling the eastern nest of monitoring wells, the City will remain in close contact with DNR staff to ensure the completed locations and elevations of the wells meet with your expectations. We propose to drill the deeper TCW well first, since the elevation of that aquifer is fairly well understood. During the drilling process, we will document the drift aquifer layers that are present at the well site. A gamma log is also proposed to help differentiate the drift layers. In cooperation with DNR staff, the optimal depth to complete the drift aquifer monitoring well will be determined.

By working closely with you to determine the best depth and locations for these monitoring wells, the expectations are that wells will be optimally situated to provide the data required to make amendments to the City's water appropriation permit to accommodate proposed Well No. 10. We understand that any permitting effort for Well No. 10 may also include an aquifer pumping test, where additional data measurements and increased measuring frequency may be required.

At your earliest convenience, please verify whether the information in this letter accurately reflects the results of our September 8, 2016 meeting and outlines an acceptable plan for developing our monitoring well network. With your approval of this plan, the City will begin the process to solicit bids from contractors to move forward with well construction in the coming year.

Sincerely,



Matt Haefner
Water and Sewer Superintendent
City of Chaska

Cc. Scott Pearson, Minnesota Department of Natural Resources
Mary Coburn, Minnesota Department of Natural Resources
Bill Monk, City of Chaska - Engineering
Matt Clark, City of Chaska - Engineering
Mark Rolfs, Stantec Consulting Services Inc.
Mark Janovec, Stantec Consulting Services Inc.

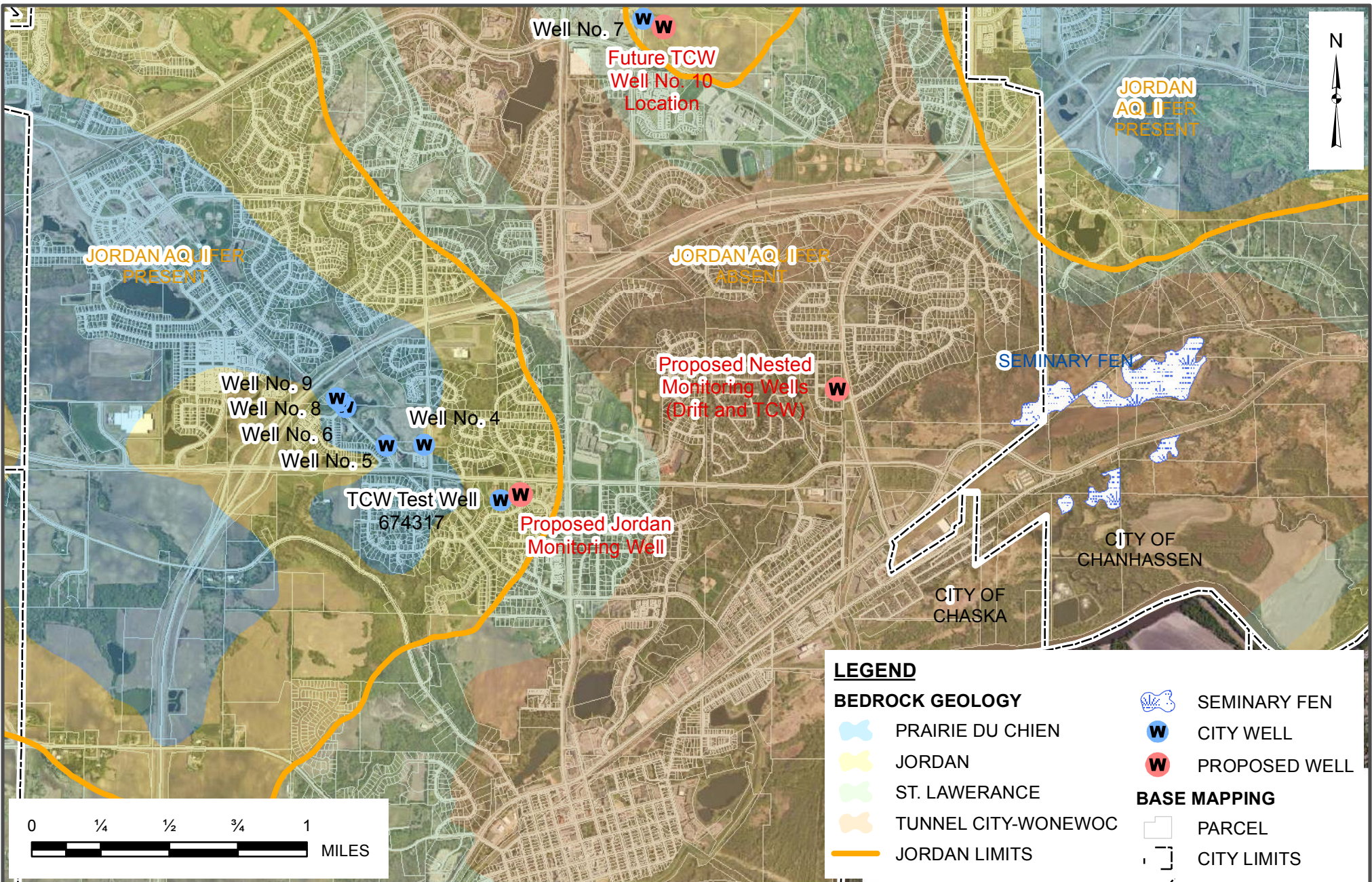

2335 Highway 36 West
 Saint Paul, MN 55113
 651.636.4600

SEPTEMBER 2016

FIGURE 1 - PROPOSED MONITORING WELL LOCATIONS

CITY OF CHASKA

The information on this map has been compiled by Stantec staff from a variety of sources and is subject to change without notice. Stantec makes no representations or warranties, express or implied, as to accuracy, completeness, timeliness, or rights to the use of such information.

V:\1938\active\193803439\GIS\Projects\Chaska proposed monitoring wells.mxd

APPENDIX 3: WATER LEVEL GRAPHS FOR EACH WATER SUPPLY WELL

System Information

Water Plant

Towers/Wells/Boosters

Trends

Lift Stations

Storm Stations

Alarms & Reports

- LS 1
- LS 2
- LS 3
- LS 4
- LS 5
- LS 8
- LS 9
- Wells Flow
- Wells DD
- Wells Temp
- Elevated Tanks
- Booster Station
- WTP Flows
- Filter Levels
- Chemical Levels
- CL2 Residual
- BW Tanks
- HS Pump Chambers

Wells Drawdown Trend Monday, October 05, 2015 - Tuesday, October 04, 2016

7/7/2016 10:29:33 AM

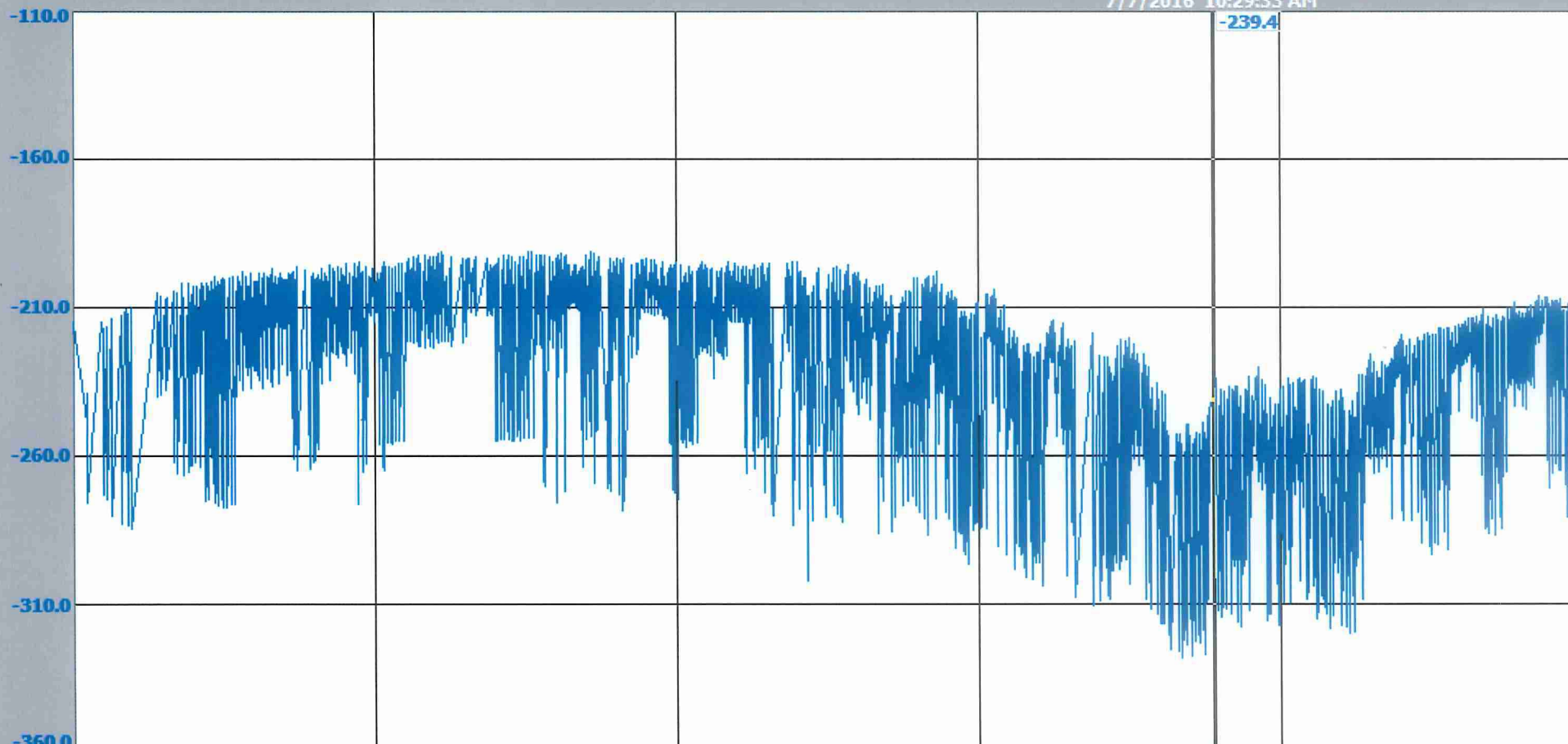

9:15:51 AM 10/5/2015 8:15:51 12/17/2015 8:15:52 2/28/2016 9:15:52 5/11/2016 9:15:53 7/23/2016 9:15:51 AM 10/4/2016

Caption

3:25:11 PM

Min

Max

Units

Well 4 - Drawdown Inverted Level

-225.1 -360.0 -110.0 Feet

Acknowledge All Alarms

Active Alarms

Station Time & Date: Monday, October 03, 2016 3:25:10 PM

Logged In: Default

Idle in 15:00

Login

Logout

Alm: 0, Sup: 0

ScreenPrint

Clear

Clear All

- System Information
- Water Plant
- Towers/Wells/Boosters
- Trends
- Lift Stations
- Storm Stations
- Alarms & Reports

- LS 1
- LS 2
- LS 3
- LS 4
- LS 5
- LS 8
- LS 9
- Wells Flow
- Wells DD
- Wells Temp
- Elevated Tanks
- Booster Station
- WTP Flows
- Filter Levels
- Chemical Levels
- CL2 Residual
- BW Tanks
- HS Pump Chambers

Wells Drawdown Trend Monday, October 05, 2015 - Tuesday, October 04, 2016

7/7/2016 10:29:33 AM

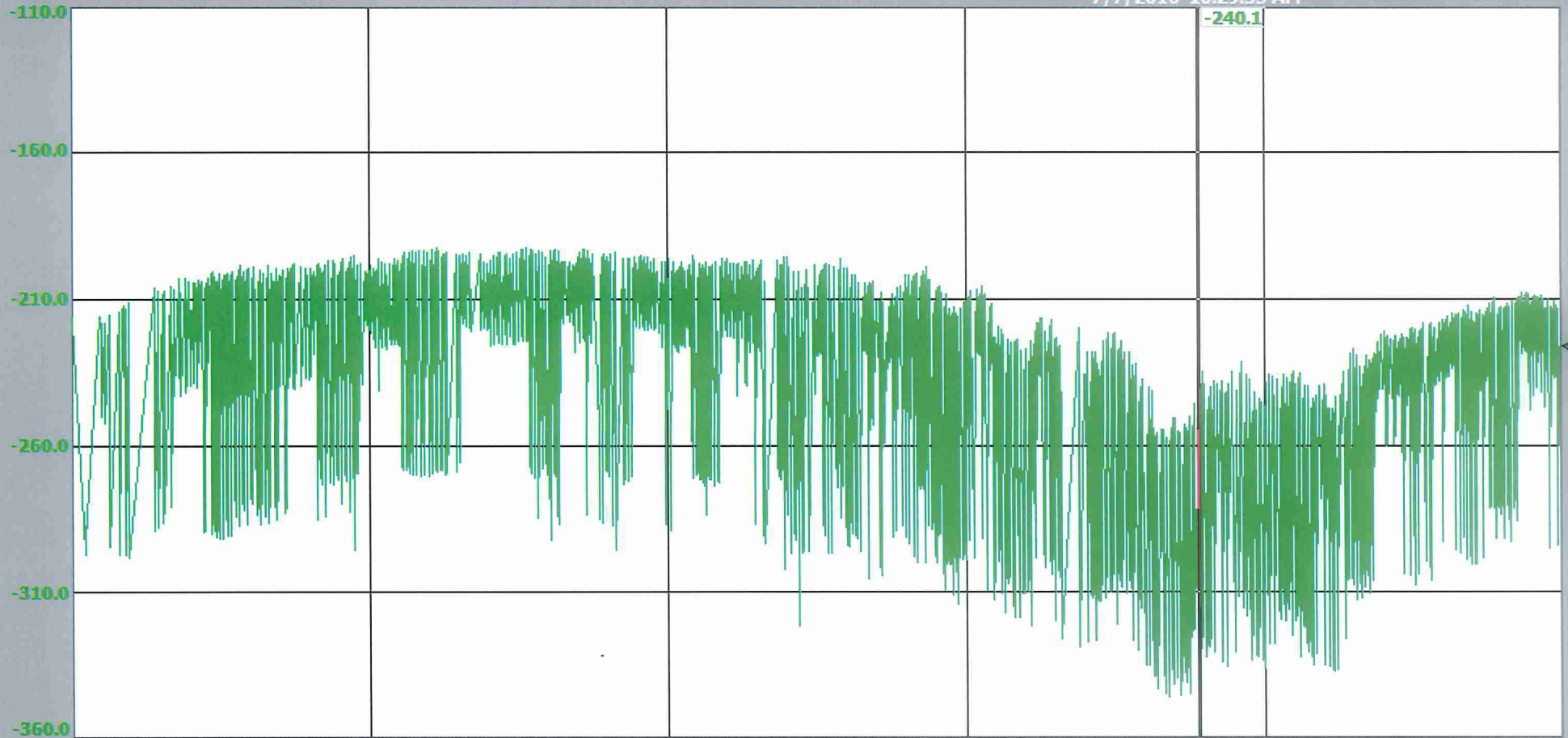

9:15:51 AM 10/5/2015 8:15:51 12/17/2015 8:15:52 2/28/2016 9:15:52 5/11/2016 9:15:53 7/23/2016 9:15:51 AM 10/4/2016

Caption	3:28:02 PM	Min	Max	Units
Well 5 - Drawdown Inverted Level		-225.5	-360.0	-110.0 Feet

Acknowledge All Alarms Active Alarms Station Time & Date: Monday, October 03, 2016 3:28:01 PM Logged In: Default Idle in 15:00 Login Logout

Alm: 0, Sup: 0

[System Information](#)
[Water Plant](#)
[Towers/Wells/Boosters](#)
[Trends](#)
[Lift Stations](#)
[Storm Stations](#)
[Alarms & Reports](#)

[LS 1](#)
[LS 2](#)
[LS 3](#)
[LS 4](#)
[LS 5](#)
[LS 8](#)
[LS 9](#)
[Wells Flow](#)
[Wells DD](#)
[Wells Temp](#)
[Elevated Tanks](#)
[Booster Station](#)
[WTP Flows](#)
[Filter Levels](#)
[Chemical Levels](#)
[CL2 Residual](#)
[BW Tanks](#)
[HS Pump Chambers](#)

Wells Drawdown Trend Monday, October 05, 2015 - Tuesday, October 04, 2016

7/7/2016 10:29:33 AM

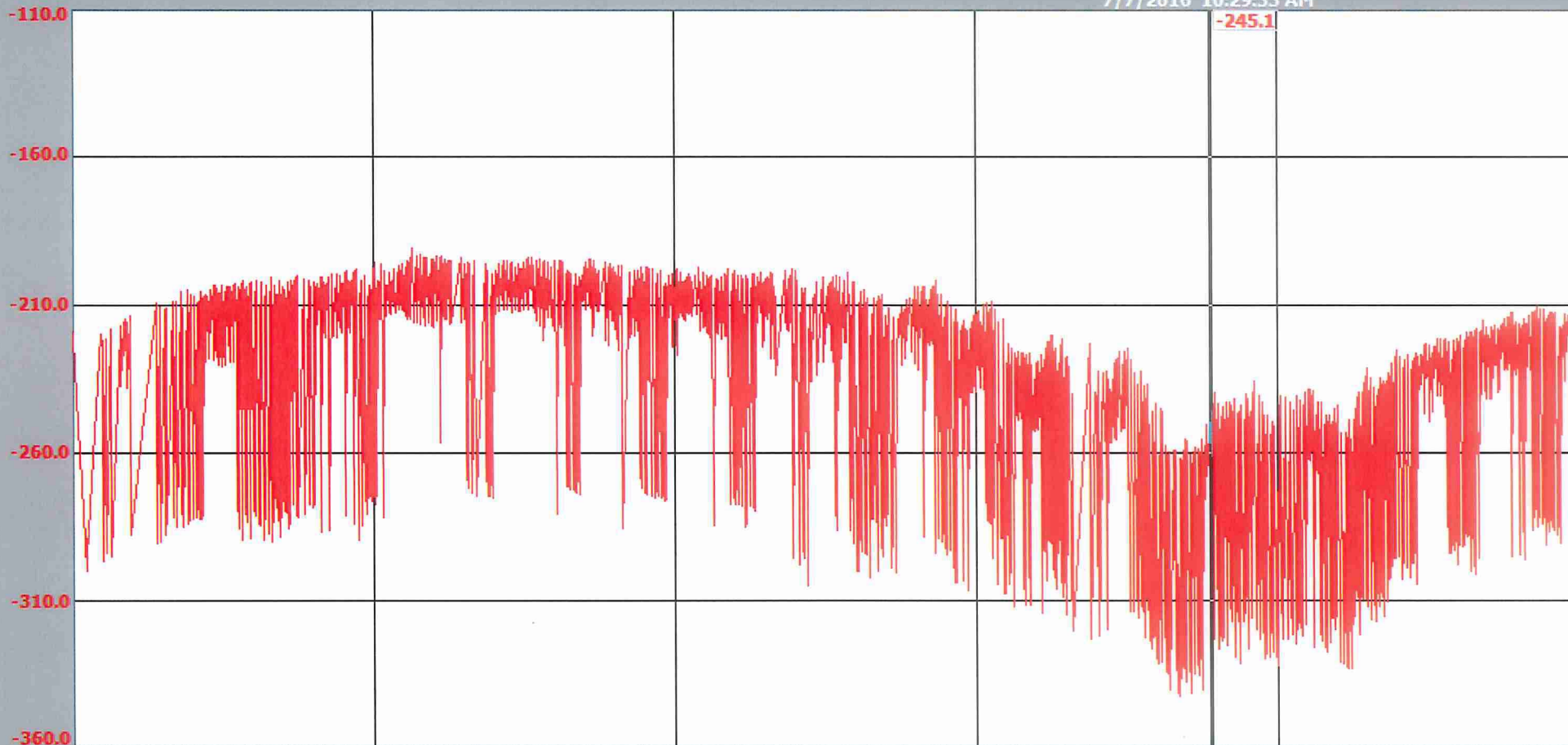

9:15:51 AM 10/5/2015 8:15:51 12/17/2015 8:15:52 2/28/2016 9:15:52 5/11/2016 9:15:53 7/23/2016 9:15:51 AM 10/4/2016

Caption	3:37:30 PM	Min	Max	Units
Well 6 - Drawdown Inverted Level	-224.7	-360.0	-110.0	Feet

[Acknowledge All Alarms](#)
[Active Alarms](#)
 Station Time & Date: Monday, October 03, 2016 3:37:29 PM
 Logged In: Default
 Idle in 15:00
 [Login](#)
[Logout](#)

Alm: 0, Sup: 0

System Information

Water Plant

Towers/Wells/Boosters

Trends

Lift Stations

Storm Stations

Alarms & Reports

- LS 1
- LS 2
- LS 3
- LS 4
- LS 5
- LS 8
- LS 9
- Wells Flow
- Wells DD
- Wells Temp
- Elevated Tanks
- Booster Station
- WTP Flows
- Filter Levels
- Chemical Levels
- CL2 Residual
- BW Tanks
- HS Pump Chambers

Wells Drawdown Trend Sunday, October 04, 2015 - Monday, October 03, 2016

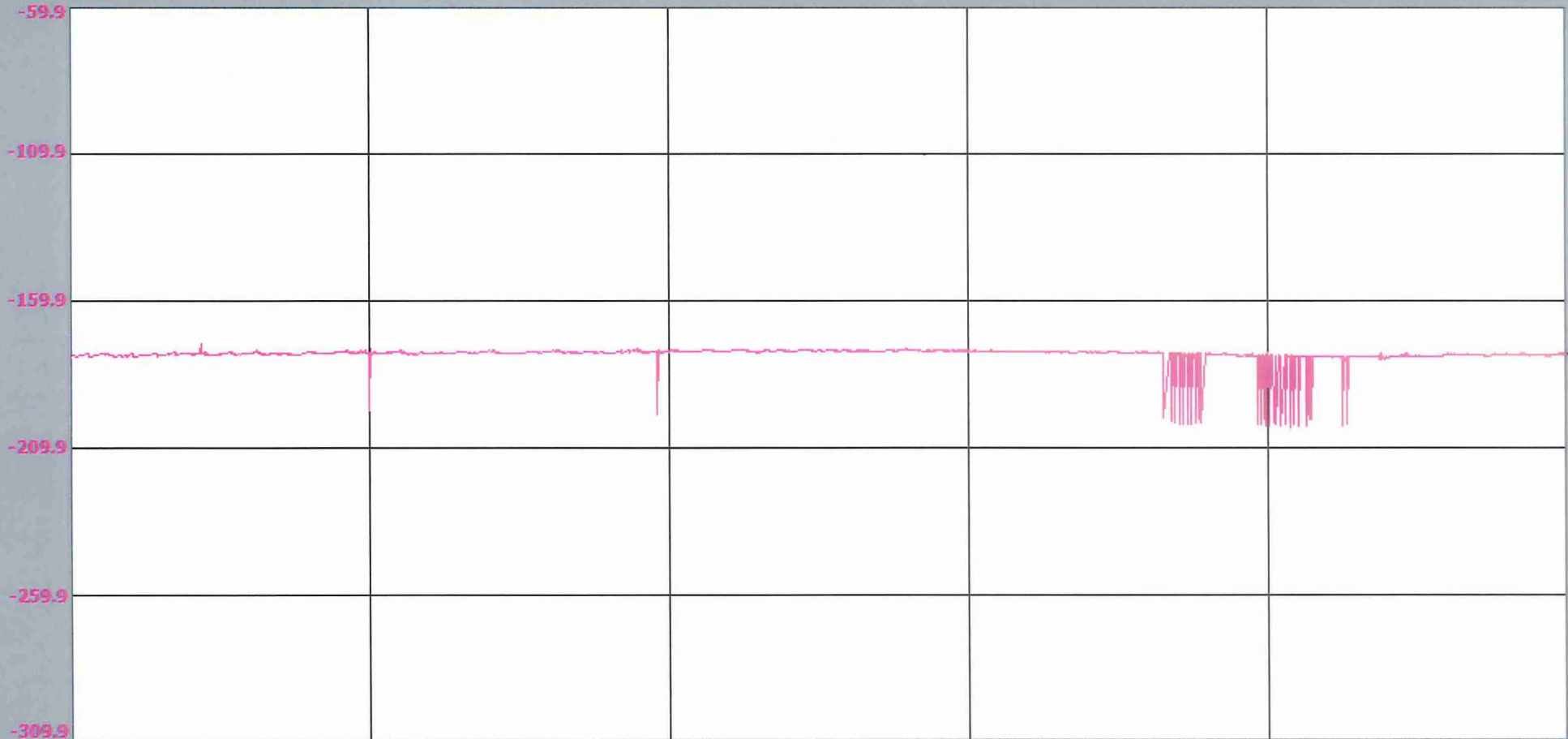

7:33:05 AM 10/4/2015 6:33:05 12/16/2015 6:33:06 2/27/2016 7:33:06 5/10/2016 7:33:07 7/22/2016 7:33:05 AM 10/3/2016

Caption	7:35:48 AM	Min	Max	Units
Well 7 - Drawdown Inverted Level	-177.5	-309.9	-59.9	Feet

Acknowledge All Alarms Active Alarms Station Time & Date: Tuesday, October 04, 2016 7:35:47 AM Logged In: Default Idle in 14:56 Login Logout

Alm: 0, Sup: 0

abort Chemicals - CL2 Residual Trend Clear Clear All

System Information

Water Plant

Towers/Wells/Boosters

Trends

Lift Stations

Storm Stations

Alarms & Reports

- LS 1
- LS 2
- LS 3
- LS 4
- LS 5
- LS 8
- LS 9
- Wells Flow
- Wells DD
- Wells Temp
- Elevated Tanks
- Booster Station
- WTP Flows
- Filter Levels
- Chemical Levels
- CL2 Residual
- BW Tanks
- HS Pump Chambers



Wells Drawdown Trend Sunday, October 04, 2015 - Monday, October 03, 2016

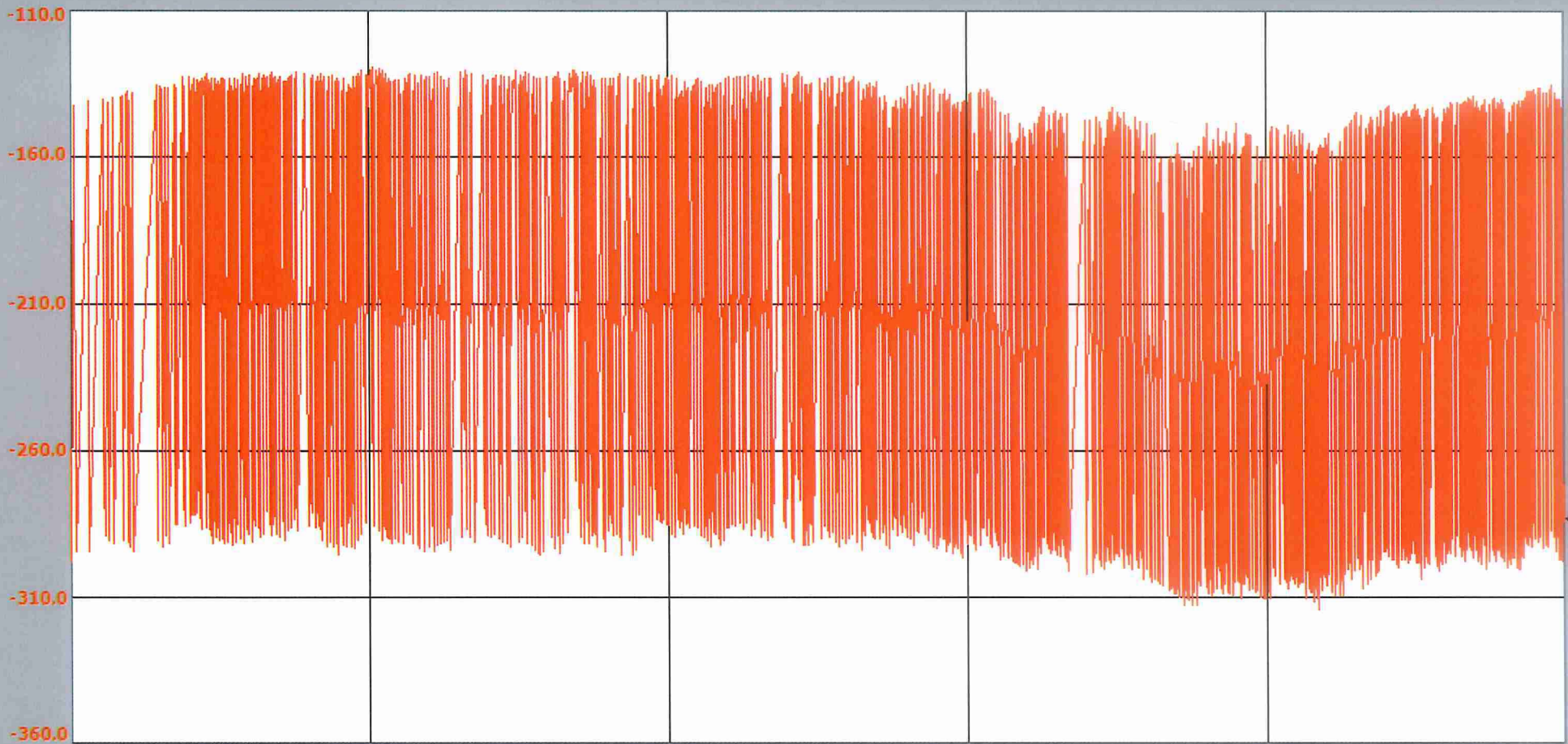

7:33:05 AM 10/4/2015 6:33:05 12/16/2015 6:33:06 2/27/2016 7:33:06 5/10/2016 7:33:07 7/22/2016 7:33:05 AM 10/3/2016

Caption	7:38:25 AM	Min	Max	Units
Well 8 - Drawdown Inverted Level	-283.0	-360.0	-110.0	Feet

[Acknowledge All Alarms](#) [Active Alarms](#) **Station Time & Date: Tuesday, October 04, 2016 7:38:25 AM** **Logged In: Default** Idle in 15:00 [Login](#) [Logout](#)

Alm: 0, Sup: 0

Display "Wells Drawdown Trend" [Clear](#) [Clear All](#)

System Information

Water Plant

Towers/Wells/Boosters

Trends

Lift Stations

Storm Stations

Alarms & Reports

- LS 1
- LS 2
- LS 3
- LS 4
- LS 5
- LS 8
- LS 9
- Wells Flow
- Wells DD
- Wells Temp
- Elevated Tanks
- Booster Station
- WTP Flows
- Filter Levels
- Chemical Levels
- CL2 Residual
- BW Tanks
- HS Pump Chambers

Wells Drawdown Trend Monday, October 05, 2015 - Tuesday, October 04, 2016

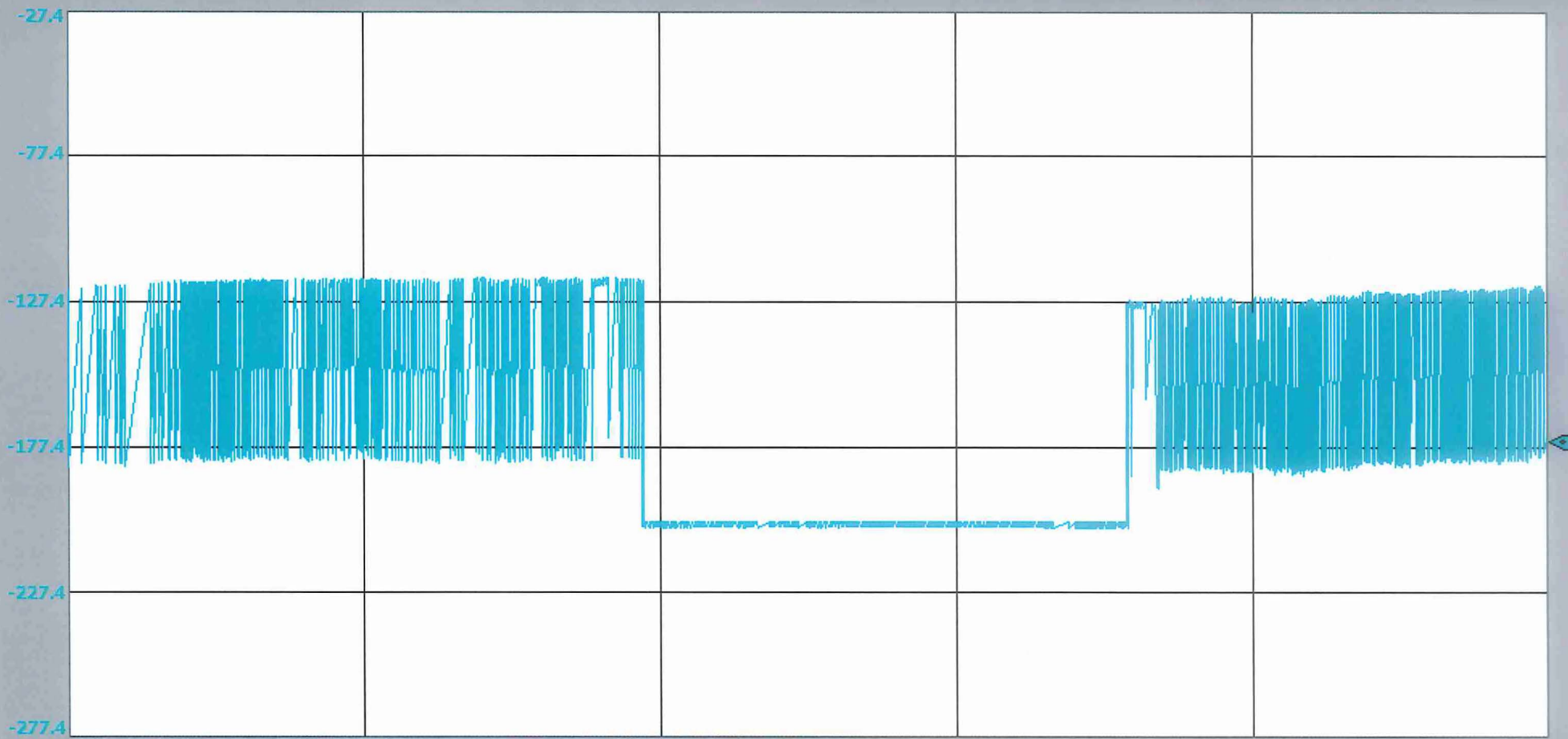

7:38:34 AM 10/5/2015 6:38:34 12/17/2015 6:38:35 2/28/2016 7:38:35 5/11/2016 7:38:36 7/23/2016 7:38:34 AM 10/4/2016

Caption

7:40:41 AM

Min

Max

Units

Well 9 - Drawdown Inverted Level -174.8 -277.4 -27.4 Feet

Acknowledge All Alarms

Active Alarms

Station Time & Date: Tuesday, October 04, 2016 7:40:39 AM

Logged In: Default

Idle in 15:00

Login

Logout

Alm: 0, Sup: 0

ScreenPrint

Clear

Clear All

WELL 4

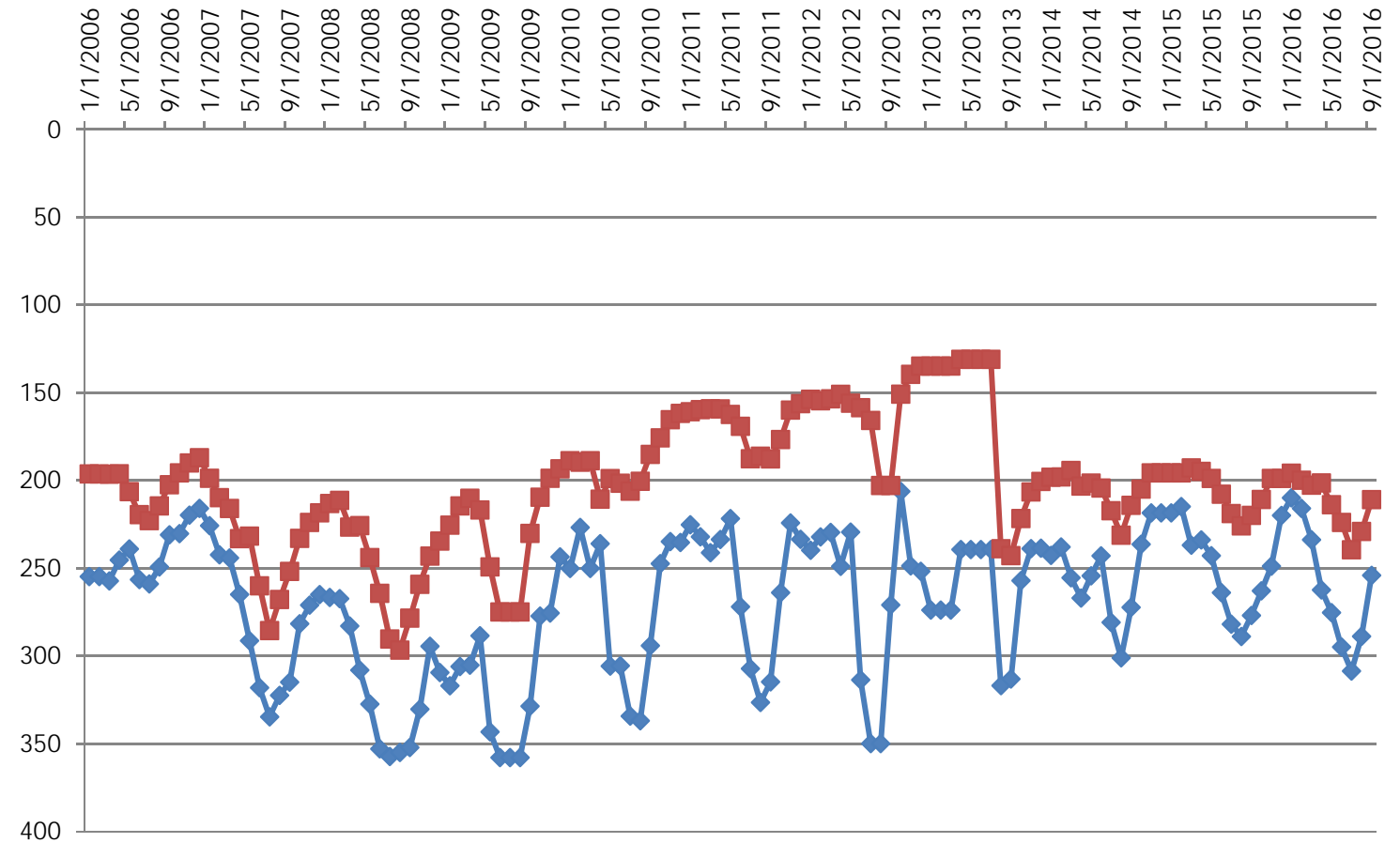

WELL 5

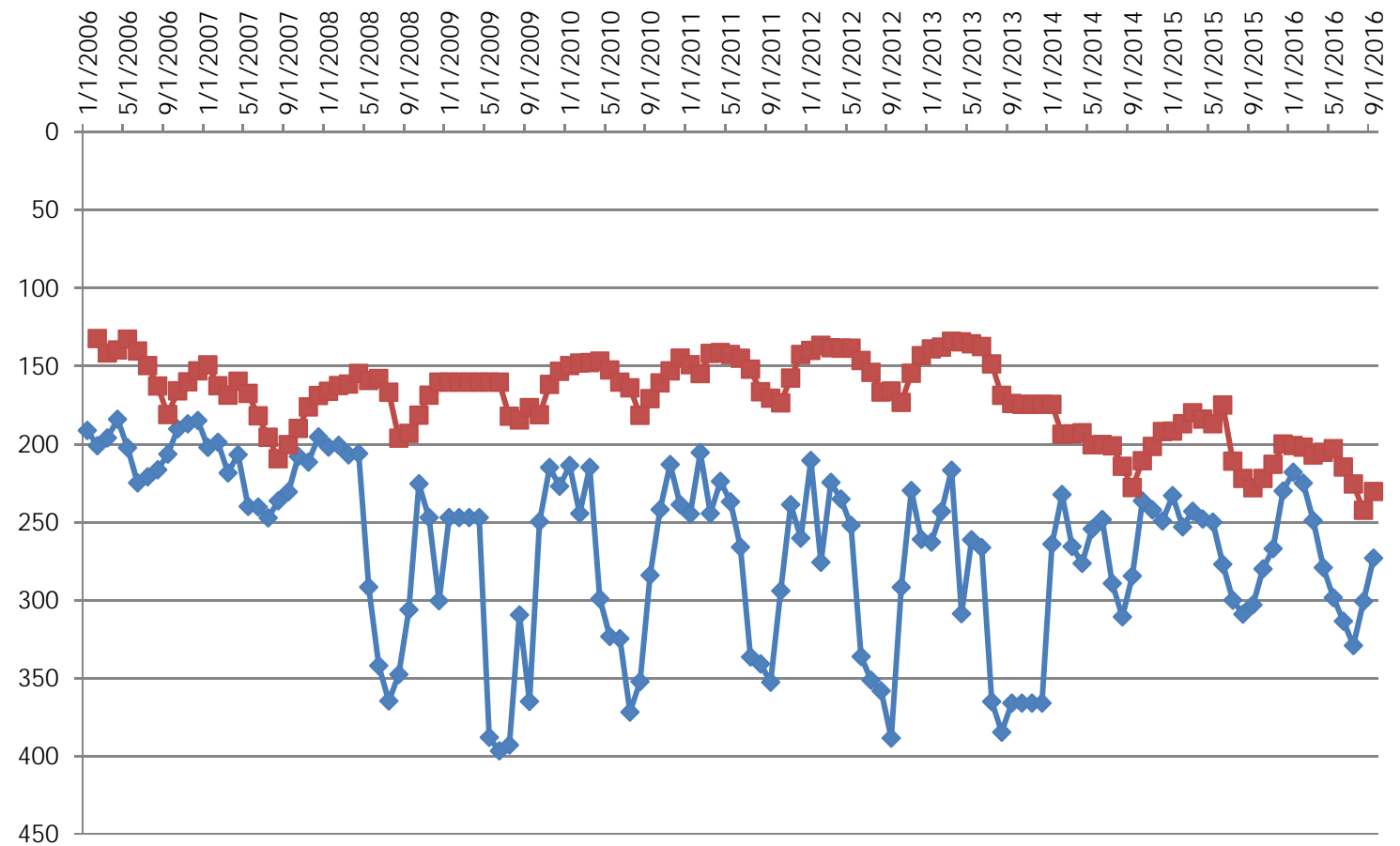

WELL 6

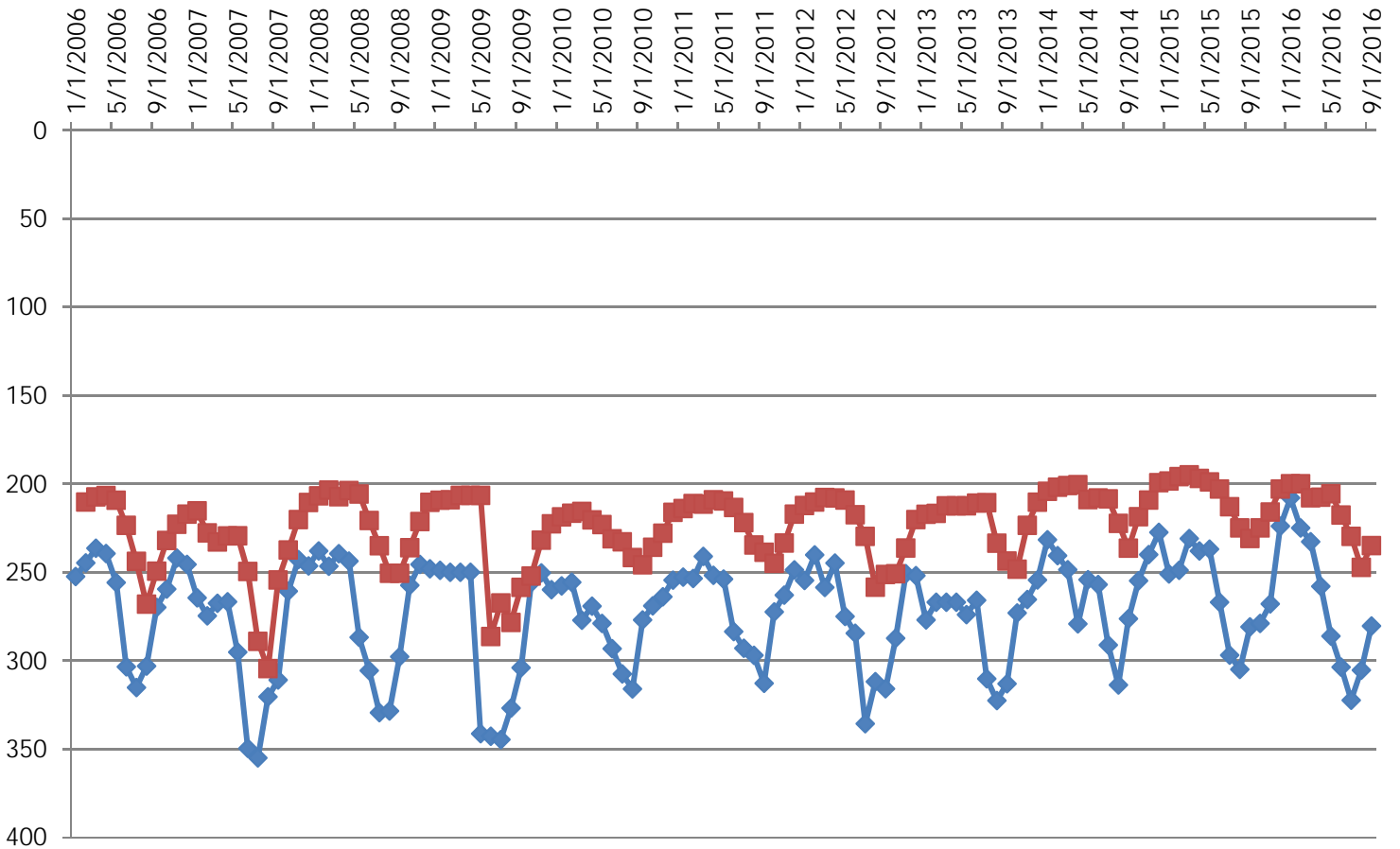

WELL 7

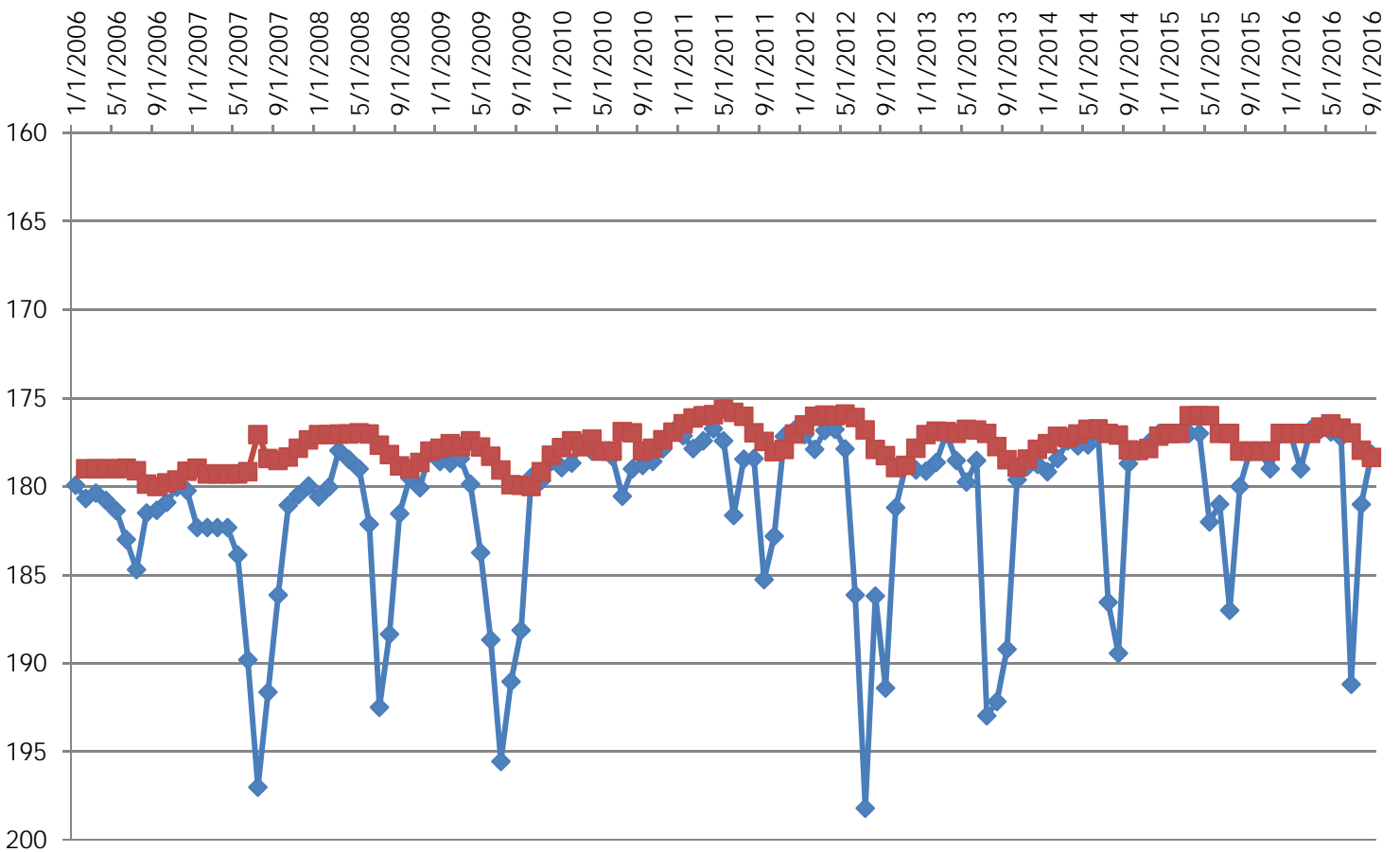

WELL 8

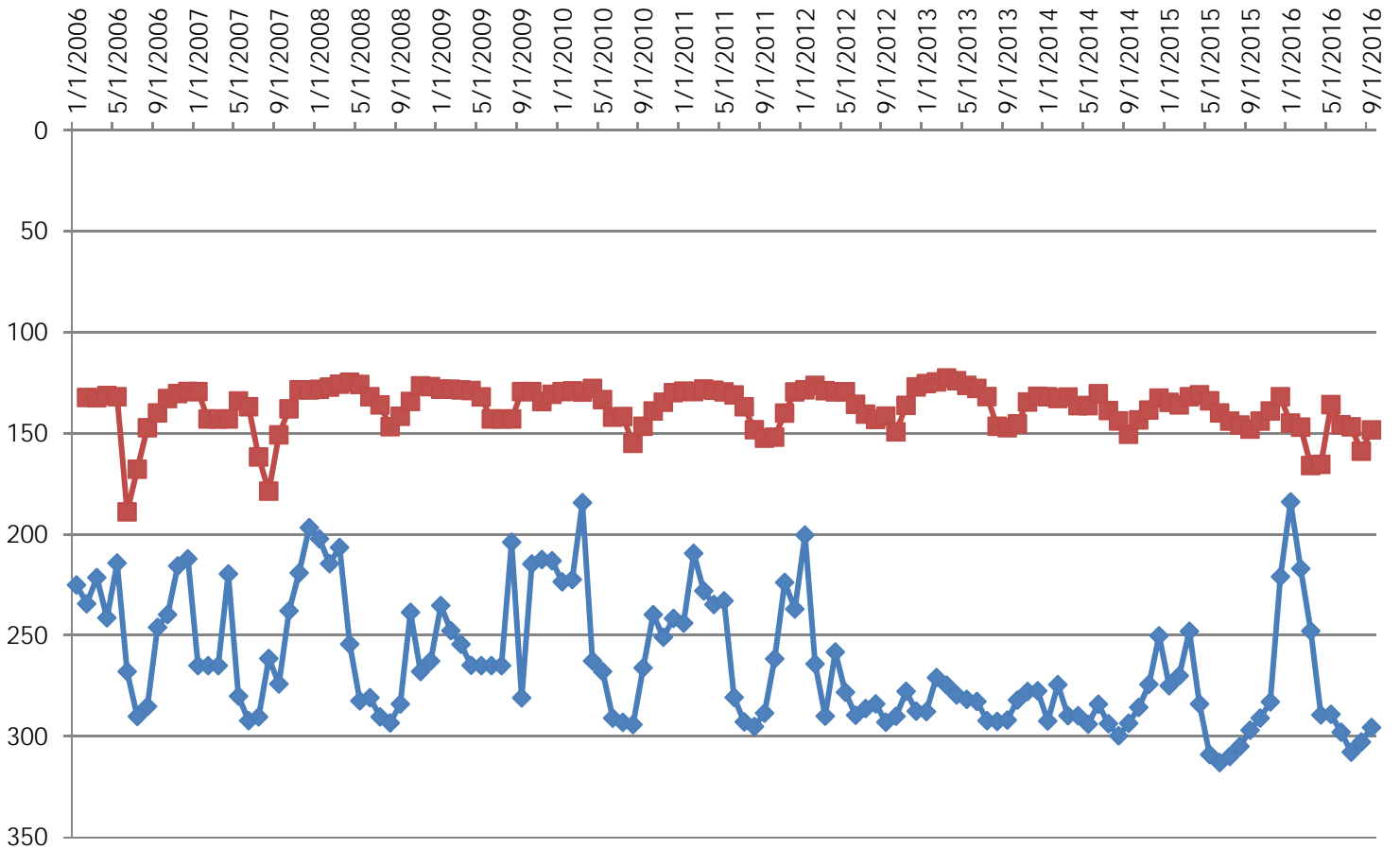

WELL 9

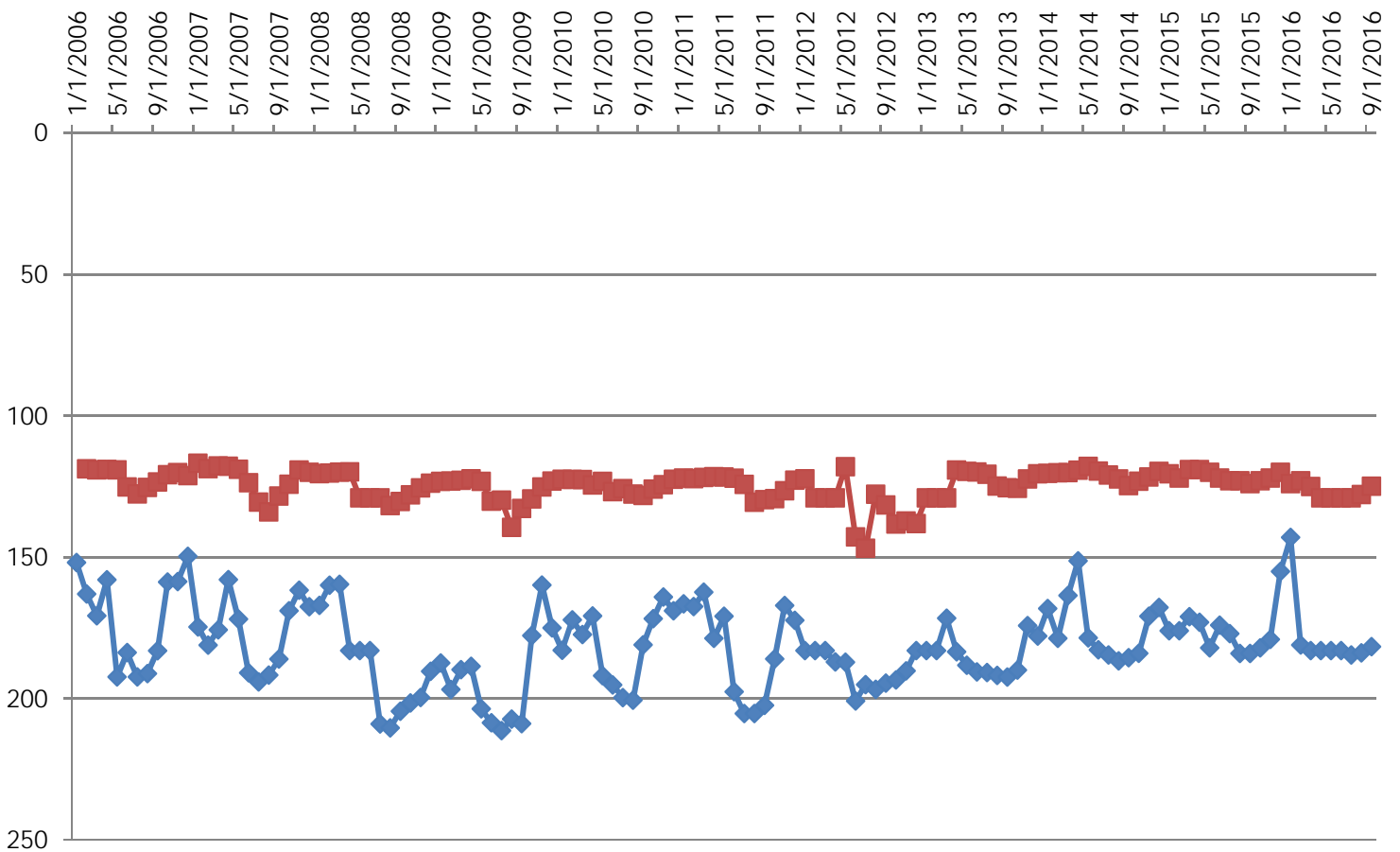

APPENDIX 4: CAPITAL IMPROVEMENT PLAN

2017 OPERATIONS & CIP MASTER WORKSHEET

WATER & SEWER	2012	2013	2014	2015	2016	2017	2018	2019	2020	2021	2022	2023	2024	Future
Additional Personnel		\$25,000							\$60,000					\$75,000
WATER														
CIP (Trunk Funded)														
Brickyard Water Connection to Highland Drive w/ PR Sta Well # 10		\$250,000		\$75,000							\$750,000			"1"
Chaska Southwest Water Tower Wells #11 & #12										\$3,000,000	"1"			\$3,000,000
Kelzer Industrial Watermain						\$50,000	\$50,000	"2"						
Frey Industrial Watermain						\$75,000	\$75,000	"2"						
Chaska Heights North Watermain			\$75,000			\$87,500	\$87,500	"3"						
Chaska Heights South Watermain			\$75,000		\$250,000	"3"								
Hammers Watermain Oversizing								\$90,000	"2"					
Hammers/SW Chaska Watermain Connection								\$250,000						
Hammers Pressure Reducing Stations (2)								\$110,000	"2"					
Brose & Glock Farms Watermain														\$1,250,000
Webber/North Chaska Watermain														\$750,000
Lano & Frenz Watermain														\$1,500,000
Raser & Kloos Farms Watermain								\$350,000						
North Side Hwy 212 Loop (Bavaria to HWY 41)														\$600,000
Stoughton Ave. Trunk Loop						\$350,000	"1"							
Zone 4 Connection Bavaria Tower to Arbor Park Trunk										\$2,000,000				"1"
New Tunnel City Well Near Well 7									\$1,000,000					
Well No. 7 Treatment									\$5,000,000	"1"				
Street Reconstruction	\$448,000	\$451,000	\$559,500	\$500,000	\$500,000	\$500,000	\$500,000	\$500,000	\$500,000					
CIP Totals	\$448,000	\$701,000	\$709,500	\$575,000	\$750,000	\$1,062,500	\$712,500	\$1,300,000	\$6,000,000	\$5,000,000	\$750,000	\$0	\$0	\$7,100,000

APPENDIX 5: EMERGENCY TELEPHONE LIST

Attachment

Emergency Telephone List

Emergency Response Team	Name	Work Telephone	Alternate Telephone
Emergency Response Lead	Matt Haefner	952-227-7733	952-448-4335
Alternate Emergency Response Lead	Brad Doerr	952-227-7705	952-448-4335
Leadman/Lead Operator	Steve Latzke	952-448-4335	
On-Call Operator	After Hours Emergencies	952-448-4335	
Public Communications	Matt Podhradsky	952-448-9200	

State and Local Emergency Response Contacts	Name	Work Telephone	Alternate Telephone
State Incident Duty Officer	Minnesota Duty Officer	800/422-0798 Out State	651-649-5451 Metro
County Emergency Director	Deb Paige	952-361-1292	
National Guard	Minnesota Duty Officer	800/422-0798 Out State	651-649-5451 Metro
Mayor	Mark Windschitl	952-448-9200	612-237-4188
Fire Chief	Tim Wiebe	952-448-2990	952-227-7457
Sheriff	Jim Olson	952-361-1212	952-361-1231
Police Chief	Scott Knight	952-448-4200	952-361-1231
Ambulance	Ridgeview	952-442-4222	952-361-1231
Hospital	Ridgeview Medical Center	952-442-2191	
Doctor or Medical Facility	Two Twelve Medical Center	952-361-2447	

State and Local Agencies	Name	Work Telephone	Alternate Telephone
MDH District Engineer	Amy Lynch	507-344-2713	
MDH	Drinking Water Protection	651-201-4700	
State Testing Laboratory	Minnesota Duty Officer	800/422-0798 Out State	651-649-5451 Metro
MPCA	MPCA	1-800-422-0798	1-800-657-3864
DNR Area Hydrologist	Jennie Skancke	651-259-5790	651-259-5800
County Water Planner	Paul Moline	952-361-1828	

Utilities	Name	Work Telephone	Alternate Telephone
Electric Company	City of Chaska	952-448-4335	612-490-9238
Gas Company	CenterPoint Energy	612-372-5050	612-332-5133
Telephone Company	CenturyLink	800-788-3600	952-442-2111
Gopher State One Call	Utility Locations	800-252-1166	651-454-0002
Highway Department	MNDot	952-905-7900	651-234-7840

Mutual Aid Agreements	Name	Work Telephone	Alternate Telephone
Neighboring Water System			
Emergency Water Connection	City of Chanhassen	952-227-1300	952-917-9345
Emergency Water Connection	City of Victoria	952-443-4210	
MNWARN Member	MNWARN	800-367-6792	651-649-5451

Technical/Contracted Services/Supplies	Name	Work Telephone	Alternate Telephone
MRWA Technical Services	MN Rural Water Association	800-367-6792	
Well Driller/Repair			
Pump Repair			
Electrician	Kloos Electric	952-448-6819	
Plumber	Diversified Plumbing	763-221-5441	
Backhoe	City of Chaska	952-448-4335	
Chemical Feed	City of Chaska	952-448-4335	

Meter Repair	City of Chaska	952-448-4335	
Generator	City of Chaska	952-448-4335	
Valves	City of Chaska	952-448-4335	
Pipe & Fittings	City of Chaska	952-448-4335	
Water Storage	City of Chaska	952-448-4335	
Laboratory	Twin City Water	952-935-3556	
Engineering firm	Stantec	651-636-4600	

Communications	Name	Work Telephone	Alternate Telephone
News Paper	Chaska Herald	952-445-3333	
Radio Station	WCCO	612-370-0611	651-989-9226
School Superintendent	Jim Bauck	952-556-6110	
Property & Casualty Insurance	LMNCIT	651-268-6993	

Critical Water Users	Name	Work Telephone	Alternate Telephone
Hospital Critical Use:	Two Twelve Medical Center	952-361-2447	
Nursing Home Critical Use:	Auburn Manor	952-448-9303	
Public Shelter Critical Use:			

APPENDIX 6: COOPERATIVE AGREEMENTS FOR EMERGENCY SERVICES

No written cooperative agreements exist for potential emergency water services.

APPENDIX 7: MUNICIPAL CRITICAL WATER DEFICIENCY ORDINANCE

Section 08. Turning on water.

No person except an authorized City employee, shall turn on any water supply at any valve or stop box without a permit from the Public Utilities Department. (Ord. No. 211, Sec. 3, 4/16/73)

Section 09. Deficiency in supply of water and shutting off water.

The City is not liable for any deficiency or failure in the supply of water to consumers, whether occasioned by shutting the water off for the purpose of making repairs or connections, or from any other cause whatsoever. In case of fire, or alarm of fire, water may be shut off to insure a supply for fire fighting, or in making repairs of construction of new works, water may be shut off at any time and kept shut off so long as necessary. (Ord. No. 211, Sec. 3, 4/16/73)

Section 10. Restricted hours of use of water.

Use of the City water supply system for lawn and garden sprinkling, irrigation, car washing or other non-potable uses shall be limited to an odd/even schedule corresponding to property address effective each year from May 1 to September 30. Whenever the City Council shall determine that a shortage of water threatens the City, it may, by Resolution, limit the times and hours during which water may be used from the City water supply; said Resolution shall state the date upon which it shall become effective, and shall be made public through whatever means of communication the Council deems appropriate and reasonable. The Public Utilities Superintendent may, on a temporary basis, issue a total ban on above water uses, without prior approval from the City Council, after contacting the City Administrator. Twenty-four (24) hours after said Resolution becomes effective any water customer who shall cause or permit water to be used in violation of said resolution shall be deemed in violation of this section and shall be subject to the penalties as set forth in Section 08 of Chapter 1. Each day said violation continues shall be considered a separate and distinct violation hereof; continued violation is hereby prohibited and shall be cause of discontinuance of water service. Special permit consideration will be given for those property owners with new seed or sod. (Ord. No. 588, Sec 1, 11-20-95)

Section 11. Connection beyond City boundaries.

Any and all connections located outside the City to the municipal water system made pursuant to agreement with the appropriate governing bodies shall be made in accordance with the applicable ordinance of the City. (Ord. No. 211, Sec. 3, 04-16-73)

Section 12. Time for connection.

If, for any cause, the plumber laying the service pipe shall fail to have the connection made at the time specified in his application, notice shall be given the Public Utilities Department fixing another day on which he wishes to make the connection. The notice must be given at least two (2) days previous to the excavation for laying the service pipe, and the connection must be made before 4:00 p.m. except in special cases, and then the work shall be done only upon a written order for the Public Utilities Department. (Ord. No. 211, Sec. 4, 4/16/73)

**APPENDIX 8: GRAPH SHOWING ANNUAL PER CAPITA WATER DEMAND
FOR EACH CUSTOMER CATEGORY DURING THE LAST TEN-YEARS**

CITY OF CHASKA PER CAPITA WATER USAGE

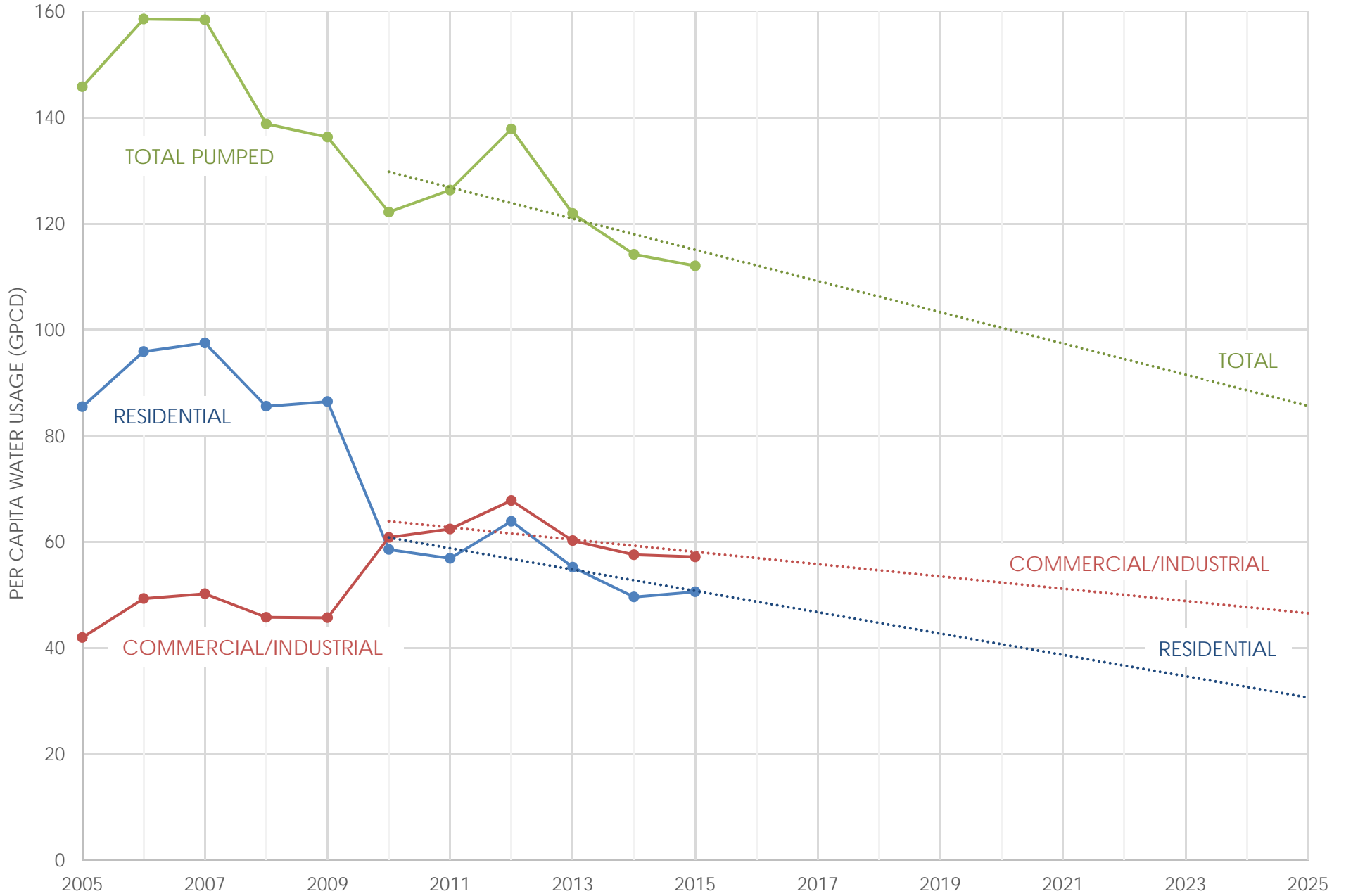

APPENDIX 9: WATER RATE STRUCTURE

WATER UTILITY

The following is a synopsis of Water Utility rates and charges per Ordinance 910 adopted January 4, 2016.

BASIC WATER RATES (per billing period)

Residential

Consumption:

0 to 7,000 gallons	\$2.27 per thousand gallons
7,001 to 20,000 gallons	\$2.39 per thousand gallons
20,001 to 30,000 gallons	\$2.58 per thousand gallons
30,001 to 40,000 gallons	\$2.90 per thousand gallons
Above 40,001 gallons	\$3.43 per thousand gallons

Commercial

Consumption:

0 to 20,000 gallons	\$1.92 per thousand gallons
Above 20,001 gallons	\$2.05 per thousand gallons

Industrial

Consumption:

0 to 90,000 gallons	\$1.70 per thousand gallons
Above 90,001 gallons	\$1.84 per thousand gallons

City of Chaska

Consumption:

0 to 7,000 gallons	\$1.49 per thousand gallons
7,001 to 20,000 gallons	\$1.56 per thousand gallons
20,001 to 30,000 gallons	\$1.68 per thousand gallons
30,001 to 40,000 gallons	\$1.90 per thousand gallons
Above 40,001 gallons	\$2.23 per thousand gallons

Irrigation Only Meters

Consumption:

0 to 20,000 gallons	\$2.43 per thousand gallons
20,001 to 40,000 gallons	\$2.90 per thousand gallons
Above 40,001 gallons	\$3.43 per thousand gallons

MONTHLY FLAT CHARGES

<u>Meter Size</u>	<u>Monthly Flat Rate per Occupancy Unit</u>	<u>Flat Rate for Safe Drinking Water</u>
5/8 inch to 3/4 inch	\$2.65	\$0.53
1 inch	\$3.60	\$0.53
1 1/2 inch	\$4.50	\$0.53
2 inch	\$7.25	\$0.53
3 inch	\$27.50	\$0.53
4 inch	\$35.05	\$0.53
5 inch	\$43.75	\$0.53
6 inch	\$52.50	\$0.53

Bulk Water (Hydrant) \$5.50 per thousand gallons

SEWER UTILITY

The following is a synopsis of Sewer Utility rates and charges per Ordinance 911 adopted January 4, 2016.

METERED SERVICE

All gallons per month-----\$3.89 per thousand gallons (based on gallons of water used)

MINIMUM CHARGES

Residential-----	\$8.95 per month
Commercial-----	\$8.95 per month
Industrial-----	\$38.60 per month
Sewer Rental Fee---	\$20.50/month
Pumping Fee---	\$6.65/month

MAXIMUM CHARGES

The sewer maximum charge shall be applied to all single family residential customers. The charge each month shall be based on the average number of gallons for the months of the previous December through and including April, adjusted to 105% of average, or the current month, whichever is less.

STORMWATER UTILITY

The following is a synopsis of Stormwater Utility charges per Resolution 16-02 adopted January 4, 2016.

RESIDENTIAL EQUIVALENCY FACTOR (REF)-----\$5.68

The Stormwater Utility charge for parcels other than single-family residential shall be calculated using the Classification of Land Use Residential Equivalency Factor (in accordance with Ordinance No. 853 adopted September 12, 2011); multiplied by the REF rate listed above, multiplied by the acreage of the parcel.

MINIMUM MONTHLY CHARGE-----\$1.00

**APPENDIX 10: ADOPTED OR PROPOSED REGULATIONS TO REDUCE
DEMAND OR IMPROVE WATER EFFICIENCY**

Section 08. Turning on water.

No person except an authorized City employee, shall turn on any water supply at any valve or stop box without a permit from the Public Utilities Department. (Ord. No. 211, Sec. 3, 4/16/73)

Section 09. Deficiency in supply of water and shutting off water.

The City is not liable for any deficiency or failure in the supply of water to consumers, whether occasioned by shutting the water off for the purpose of making repairs or connections, or from any other cause whatsoever. In case of fire, or alarm of fire, water may be shut off to insure a supply for fire fighting, or in making repairs of construction of new works, water may be shut off at any time and kept shut off so long as necessary. (Ord. No. 211, Sec. 3, 4/16/73)

Section 10. Restricted hours of use of water.

Use of the City water supply system for lawn and garden sprinkling, irrigation, car washing or other non-potable uses shall be limited to an odd/even schedule corresponding to property address effective each year from May 1 to September 30. Whenever the City Council shall determine that a shortage of water threatens the City, it may, by Resolution, limit the times and hours during which water may be used from the City water supply; said Resolution shall state the date upon which it shall become effective, and shall be made public through whatever means of communication the Council deems appropriate and reasonable. The Public Utilities Superintendent may, on a temporary basis, issue a total ban on above water uses, without prior approval from the City Council, after contacting the City Administrator. Twenty-four (24) hours after said Resolution becomes effective any water customer who shall cause or permit water to be used in violation of said resolution shall be deemed in violation of this section and shall be subject to the penalties as set forth in Section 08 of Chapter 1. Each day said violation continues shall be considered a separate and distinct violation hereof; continued violation is hereby prohibited and shall be cause of discontinuance of water service. Special permit consideration will be given for those property owners with new seed or sod. (Ord. No. 588, Sec 1, 11-20-95)

Section 11. Connection beyond City boundaries.

Any and all connections located outside the City to the municipal water system made pursuant to agreement with the appropriate governing bodies shall be made in accordance with the applicable ordinance of the City. (Ord. No. 211, Sec. 3, 04-16-73)

Section 12. Time for connection.

If, for any cause, the plumber laying the service pipe shall fail to have the connection made at the time specified in his application, notice shall be given the Public Utilities Department fixing another day on which he wishes to make the connection. The notice must be given at least two (2) days previous to the excavation for laying the service pipe, and the connection must be made before 4:00 p.m. except in special cases, and then the work shall be done only upon a written order for the Public Utilities Department. (Ord. No. 211, Sec. 4, 4/16/73)

APPENDIX 11: IMPLEMENTATION CHECKLIST

Appendix 11. Implementation Checklist

Water Supply Plan Section	Page	Water Supply Plan Action	Implementation Status/Date
Part 1E Appendix 2	10	Well Level Monitoring Plan for hourly data collection and planned monitoring wells as detailed in Appendix 2.	Ongoing
Part 1E	14	Complete ongoing update of Chaska Wellhead Protection Plan.	2017
Part 3 Part 3E	24 36	Continue Meter Leak Alert Program: Immediately notify customers of detected leak through automatic meter system.	Ongoing
Part 3B, Obj. 1	26	Maintain current low unaccounted for water percentage. Identify and repair leaks immediately.	Ongoing
Part 3B, Obj. 2	27	Revise water ordinance to limit irrigation. Eliminate day time irrigation (no watering between noon and 4 pm.	2017
Part 3B, Obj. 2	27	Infrastructure improvements to prevent water loss through preventative maintenance and proactive replacement of water system infrastructure.	Ongoing
Part 3B, Obj. 1 Part 3B, Obj. 2	28 28	Existing Meter Leak Alert Program to detect spikes in consumption at residential and nonresidential customers; daily response to alerts.	Ongoing
Part 3B, Obj. 3 Part 3E	28 35	Train Utility employees to provide conservation education to customers.	2017
Part 3B, Obj. 4	29	Existing per capita water demand trends are trending downward. Continue to monitor per capita demand.	Ongoing
Part 3B, Obj. 5	29	Monitor and maintain the maximum day demand to average day demand ratio below the DNR target of 2.6.	Ongoing
Part 3B, Obj. 6	30	City of Chaska water rate structure promotes conservation.	Ongoing
Part 3B, Obj. 7	32	No new private wells within the City USA and once municipal water service is available private wells not allowed for domestic use (Ordinance 25).	Ongoing
Part 3C	33	Water efficient plumbing fixtures and irrigation rainfall sensors required by existing Federal Law and State Statue, respectively.	Ongoing
Part 3C	33	Critical/Emergency Water Deficiency ordinance in place (Ordinance 25).	Ongoing
Part 3C	33	Water Restriction Requirements as detailed in Ordinance 25.	Ongoing
Part 3C	33	Soil preparation requirements: Carver County requires a minimum of 6" of topsoil and standards for topsoil borrow.	Ongoing
Part 3E	35	Billing inserts included seasonally to educate customers on irrigation restrictions and associated fines for violation.	Ongoing
Part 3E	35	Consumer confidence report to include water quality and water conservation topics for customer education.	Ongoing
Part 3E	35	Traditional press releases during declared emergencies.	During emergencies
Part 3E	35 36	Water conservation education, water restriction information, and emergency notices distributed through social media.	Ongoing
Part 3E	35	Providing water utility and water conservation education during facility tours for customers and general public.	Ongoing
Part 3E	35	General water conservation literature provided at Utility and City Hall.	Ongoing
Part 3E	36	Leak identification and water conservation topics on City website. www.chaskamn.com	Ongoing Expand in 2017
Part 3E	36	Develop emergency conservation notices ahead of emergency so documents are ready for distribution in an emergency.	Ongoing
Part 3E	36	Bundle conservation materials and have available for when customers request information on conservation or how to reduce their water bill.	2017